

# 1" (25mm) HEAVY DUTY BOLTED STYLE PUMP

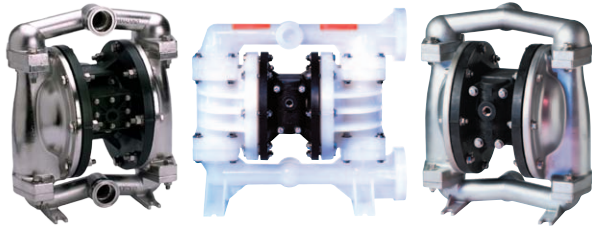

## 1" (25mm) HEAVY DUTY BOLTED STYLE PUMP

Engineered for maximum fluid and chemical compatibility. Heavy duty, non-metallic air section ensures stall free and freeze free operation. Bolted design provides ease of maintenance and leak free operation. Available in a variety of materials and options.

- Suitable for Clean Fluids, Slurries or up to 1/4" Solids
- All-Pur FDA Elastomers and Electropassivated Stainless Available
- Heavy Duty Air Valve
- Available in Metallic or Non-Metallic Wetted Components
- Muffler Included

## SPECIFICATIONS

Dimension	
Physical Dimensions	See Drawing Page 75/76
Air Inlet	1/4"
Liquid Inlet	1" (25 mm)
Liquid Outlet	1" (25 mm)
Weight	See Product Tables
Performance	
Maximum Flow	41 gpm (155.8 lpm)
Maximum Air Pressure	120 psi (8.2 bar)
Maximum Solids	1/4" (6.4 mm)
Max Suction Lift Dry	15 ft (4.5 m)
Max Suction Lift Wet	26 ft (7.9 m)
Max Suction Lift Dry with PTFE	10 ft (3 m)
Max Temperature	See Product Tables
Noise Level (with muffler)	80 dBA
Displacement Per Stroke	0.083 Gallons (0.314 l)



PERFORMANCE CURVE (Based on water-flooded suction)

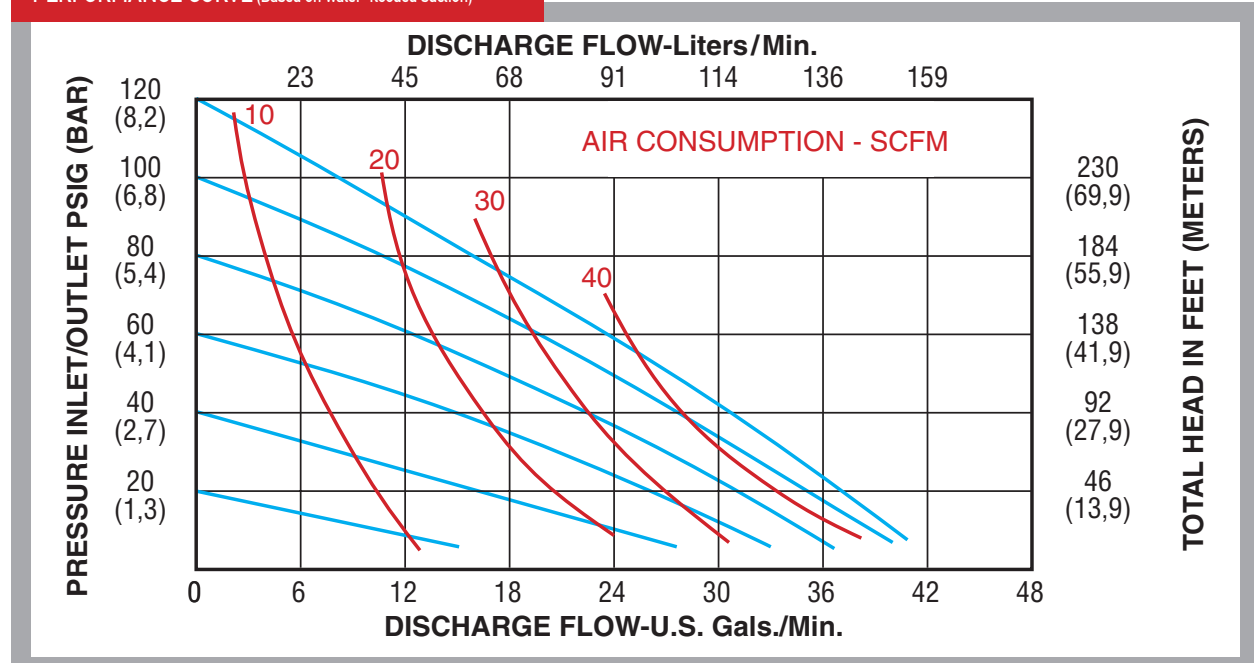

**1" (25mm) - ALUMINUM** - General purpose pump, suitable for water, oils, most solvents, and most paints. Please consult chemical compatibility tables or [www.all-flo.com](http://www.all-flo.com) for your particular application.

PART NUMBER	DIAPHRAGM MATERIAL	VALVE/BALL MATERIAL	VALVE SEAT MATERIAL	O-RING MATERIAL	FASTENER MATERIAL	WEIGHT LBS (KG)	MAX TEMPERATURE °F (°C)	DIMENSIONAL DIAGRAM	CONNECT TYPE
AN-10	Geolast®	Nitrile	Polypropylene	Nitrile	SS	28 (12.7)	180 (82)	Pg. 76	NPT
AB-10	Geolast®	Geolast®	Polypropylene	Nitrile	SS	28 (12.7)	180 (82)	Pg. 76	NPT
AB-10-B2	Geolast®	PTFE	Polypropylene	Nitrile	SS	28 (12.7)	180 (82)	Pg. 76	NPT
AT-10	PTFE	PTFE	Nylon	PTFE	SS	28 (12.7)	212 (100)	Pg. 76	NPT
AE-10	Santoprene®	Santoprene®	Polypropylene	EPDM	SS	28 (12.7)	212 (100)	Pg. 76	NPT
AV-10	Viton®	Viton®	Nylon	Viton®	SS	28 (12.7)	212 (100)	Pg. 76	NPT
AN-10-P15	Geolast®	Nitrile	Polypropylene	Nitrile	SS	28 (12.7)	180 (82)	Pg. 76	BSP
AB-10-P15	Geolast®	Geolast®	Polypropylene	Nitrile	SS	28 (12.7)	180 (82)	Pg. 76	BSP
AB-10-B2-P15	Geolast®	PTFE	Polypropylene	Nitrile	SS	28 (12.7)	180 (82)	Pg. 76	BSP
AT-10-P15	PTFE	PTFE	Nylon	PTFE	SS	28 (12.7)	212 (100)	Pg. 76	BSP
AE-10-P15	Santoprene®	Santoprene®	Polypropylene	EPDM	SS	28 (12.7)	212 (100)	Pg. 76	BSP
AV-10-P15	Viton®	Viton®	Nylon	Viton®	SS	28 (12.7)	212 (100)	Pg. 76	BSP

**1" (25mm) - 316 SS** - Corrosion resistant steel, suitable for nitric acid, chlorinated solvents, caustics and marine applications. Please consult chemical compatibility tables or [www.all-flo.com](http://www.all-flo.com) for your particular application.

PART NUMBER	DIAPHRAGM MATERIAL	VALVE/BALL MATERIAL	VALVE SEAT MATERIAL	O-RING MATERIAL	FASTENER MATERIAL	WEIGHT LBS (KG)	MAX TEMPERATURE °F (°C)	DIMENSIONAL DIAGRAM	CONNECT TYPE
SN-10	Geolast®	Nitrile	SS	Nitrile	SS	56 (25.4)	180 (82)	Pg. 76	NPT
SB-10	Geolast®	Geolast®	SS	Nitrile	SS	56 (25.4)	180 (82)	Pg. 76	NPT
SP-10	PTFE	PTFE	SS	PTFE	SS	56 (25.4)	212 (100)	Pg. 76	NPT
SE-10	Santoprene®	Santoprene®	SS	EPDM	SS	56 (25.4)	212 (100)	Pg. 76	NPT
SV-10	Viton®	Viton®	SS	Viton®	SS	56 (25.4)	212 (100)	Pg. 76	NPT
SN-10-P15	Geolast®	Nitrile	SS	Nitrile	SS	56 (25.4)	180 (82)	Pg. 76	BSP
SB-10-P15	Geolast®	Geolast®	SS	Nitrile	SS	56 (25.4)	180 (82)	Pg. 76	BSP
SP-10-P15	PTFE	PTFE	SS	PTFE	SS	56 (25.4)	212 (100)	Pg. 76	BSP
SE-10-P15	Santoprene®	Santoprene®	SS	EPDM	SS	56 (25.4)	212 (100)	Pg. 76	BSP
SV-10-P15	Viton®	Viton®	SS	Viton®	SS	56 (25.4)	212 (100)	Pg. 76	BSP

**ALL-PÜR 1" (25mm) - ELECTROPOLISHED & PASSIVATED 316 SS** - FDA elastomers and corrosion resistant steel. Suitable for food and sanitary applications. Please consult chemical compatibility tables or [www.all-flo.com](http://www.all-flo.com) for your particular application.

PART NUMBER	DIAPHRAGM MATERIAL	VALVE/BALL MATERIAL	VALVE SEAT MATERIAL	O-RING MATERIAL	FASTENER MATERIAL	WEIGHT LBS (KG)	MAX TEMP °F (°C)	DIMENSIONAL DIAGRAM	CONNECT TYPE
SB-10-X44	FDA Hytrel®	FDA Nitrile®	SS	FDA Nitrile®	SS	56 (25.4)	180 (82)	Pg. 76	1 1/2" Tri-Clamp
SP-10-X44	FDA PTFE	FDA PTFE	SS	FDA PTFE	SS	56 (25.4)	212 (100)	Pg. 76	1 1/2" Tri-Clamp
SE-10-X44	Santoprene®	Santoprene®	SS	FDA EPDM	SS	56 (25.4)	212 (100)	Pg. 76	1 1/2" Tri-Clamp

**1" (25mm) - POLYPROPYLENE** - A non-metallic material, suitable for water, caustics, soap solutions, mild acids and general purpose applications. Please consult chemical compatibility tables or [www.all-flo.com](http://www.all-flo.com) for your particular application.

PART NUMBER	DIAPHRAGM MATERIAL	VALVE/BALL MATERIAL	VALVE SEAT MATERIAL	O-RING MATERIAL	FASTENER MATERIAL	WEIGHT LBS (KG)	MAX TEMP °F (°C)	DIMENSIONAL DIAGRAM	CONNECT TYPE
PN-10	Geolast®	Nitrile	Polypropylene	Nitrile	SS	26 (11.8)	150 (66)	Pg. 75	ANSI / DIN Flange
PB-10	Geolast®	Geolast®	Polypropylene	Nitrile	SS	26 (11.8)	150 (66)	Pg. 75	ANSI / DIN Flange
PT-10	PTFE	PTFE	Polypropylene	PTFE	SS	26 (11.8)	150 (66)	Pg. 75	ANSI / DIN Flange
PE-10	Santoprene®	Santoprene®	Polypropylene	EPDM	SS	26 (11.8)	150 (66)	Pg. 75	ANSI / DIN Flange
PV-10	Viton®	Viton®	Polypropylene	Viton®	SS	26 (11.8)	150 (66)	Pg. 75	ANSI / DIN Flange

# 1" (25mm) HEAVY DUTY BOLTED STYLE PUMP

**1" (25mm) - PVDF** - Polyvinylidene fluoride suitable in applications requiring the highest purity, strength, and resistance to solvents, acids, and bases. Please consult chemical compatibility tables or [www.all-flo.com](http://www.all-flo.com) for your particular application.

PART NUMBER	DIAPHRAGM MATERIAL	VALVE/BALL MATERIAL	VALVE SEAT MATERIAL	O-RING MATERIAL	FASTENER MATERIAL	WEIGHT LBS (KG)	MAX TEMP °F (°C)	DIMENSIONAL DIAGRAM	CONNECT TYPE
KT-10	PTFE	PTFE	PVDF	PTFE	SS	36 (16.3)	200 (93)	Pg. 75	ANSI / DIN Flange
KE-10	Santoprene®	Santoprene®	PVDF	EPDM	SS	36 (16.3)	200 (93)	Pg. 75	ANSI / DIN Flange
KV-10	Viton®	Viton®	PVDF	Viton®	SS	36 (16.3)	200 (93)	Pg. 75	ANSI / DIN Flange

**AVAILABLE OPTIONS** - Each pump can be configured to suit a particular application. Please see the options section for detailed product information on the following available options.

<b>AIR VALVE OPTIONS</b>		SEE PAGE 67
CYCLE COUNT VALVE	SOLENOID ADAPTOR VALVE	
<b>BALL VALVE OPTIONS</b>		SEE PAGE 67
GEOLAST®	PTFE	
SANTOPRENE®	HEAVY NITRILE	
FDA NITRILE	STAINLESS STEEL	
<b>HARDWARE OPTIONS</b>		SEE PAGE 67
PTFE COATED HARDWARE		
<b>O-RINGS</b>		SEE PAGE 67
PTFE O-RINGS	NITRILE O-RINGS	
EPDM O-RINGS	VITON® O-RINGS	
<b>PORTING OPTIONS</b>		SEE PAGE 68
BSP THREADS	ALL PORTS OPEN	
DISCHARGE AIR INLET / EXHAUST		
SUCTION / AIR INLET / EXHAUST		
SUCTION / DISCHARGE LEFT		
SUCTION RIGHT & DISCHARGE LEFT		
SUCTION LEFT & DISCHARGE RIGHT		
<b>VALVE SEAT OPTIONS</b>		SEE PAGE 68
POLYPROPYLENE	NYLON	
PVDF	STAINLESS STEEL	

**AVAILABLE ACCESSORIES** - Please see the accessories section for detailed product information on the following available accessories.

AIR	SEE PAGE
FILTER / REGULATOR / GAUGE	60
SOLENOID VALVES	60
AIR FLOW CONTROL VALVES	60
NEEDLE VALVE	60
<b>LIQUID</b>	
COMPANION FLANGE KIT	61
SUCTION STRAINER	61
<b>PUMP</b>	
GROUNDING LUG	64



**METALLIC**  
Our 1" metallic pumps, available in both stainless steel and aluminum, can be fitted with a wide variety of elastomers to suit your application.



**NON-METALLIC**  
Wetted chambers available in polypropylene or PVDF. Diaphragms available in PTFE, Santoprene® or Viton®. Multiple liquid porting options available.



**ALL-PUR FDA PUMPS**  
Electropolished and passivated 316 SS with FDA approved elastomers and tri-clamps for sanitary applications.

### 1/2" CLAMPED STYLE HEAVY DUTY PUMP (PLASTIC)

Dimensions in inches and (mm). Ports shown facing front for dimensional purposes.  
For detailed dimensional drawings, please visit [www.all-flo.com](http://www.all-flo.com)

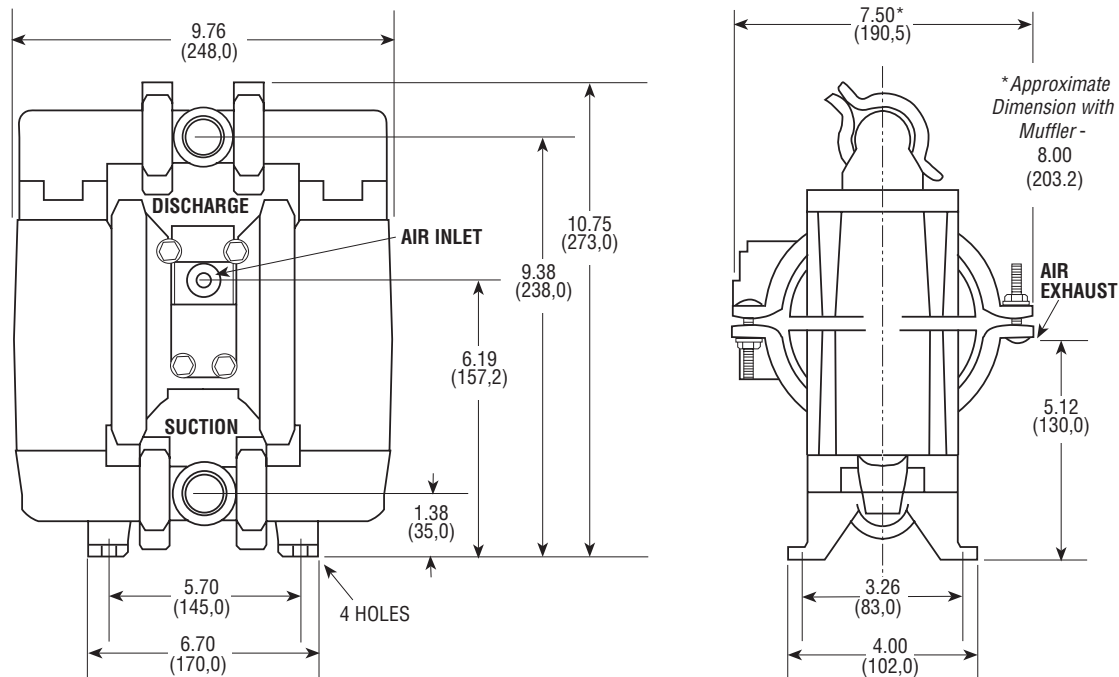

### 1" BOLTED STYLE HEAVY DUTY PUMP (PLASTIC)

Dimensions in inches and (mm). For detailed dimensional drawings, please visit [www.all-flo.com](http://www.all-flo.com)

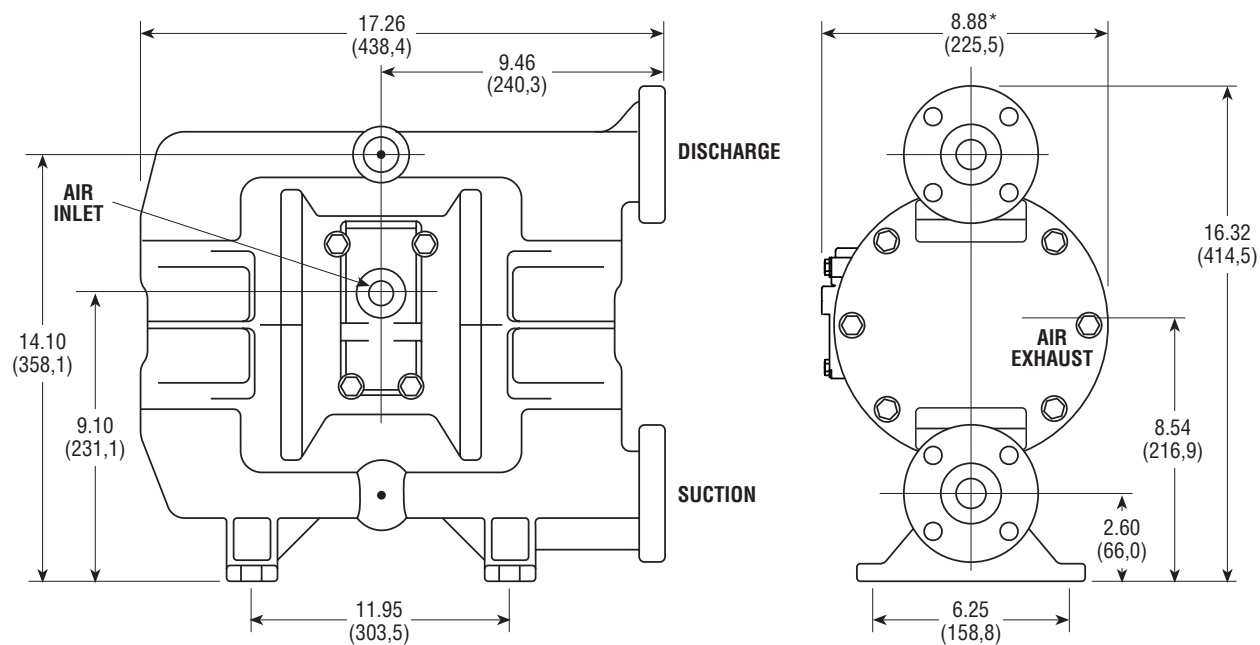

### 1" BOLTED STYLE HEAVY DUTY PUMP (METALLIC)

Dimensions in inches and (mm). For detailed dimensional drawings, please visit [www.all-flo.com](http://www.all-flo.com)

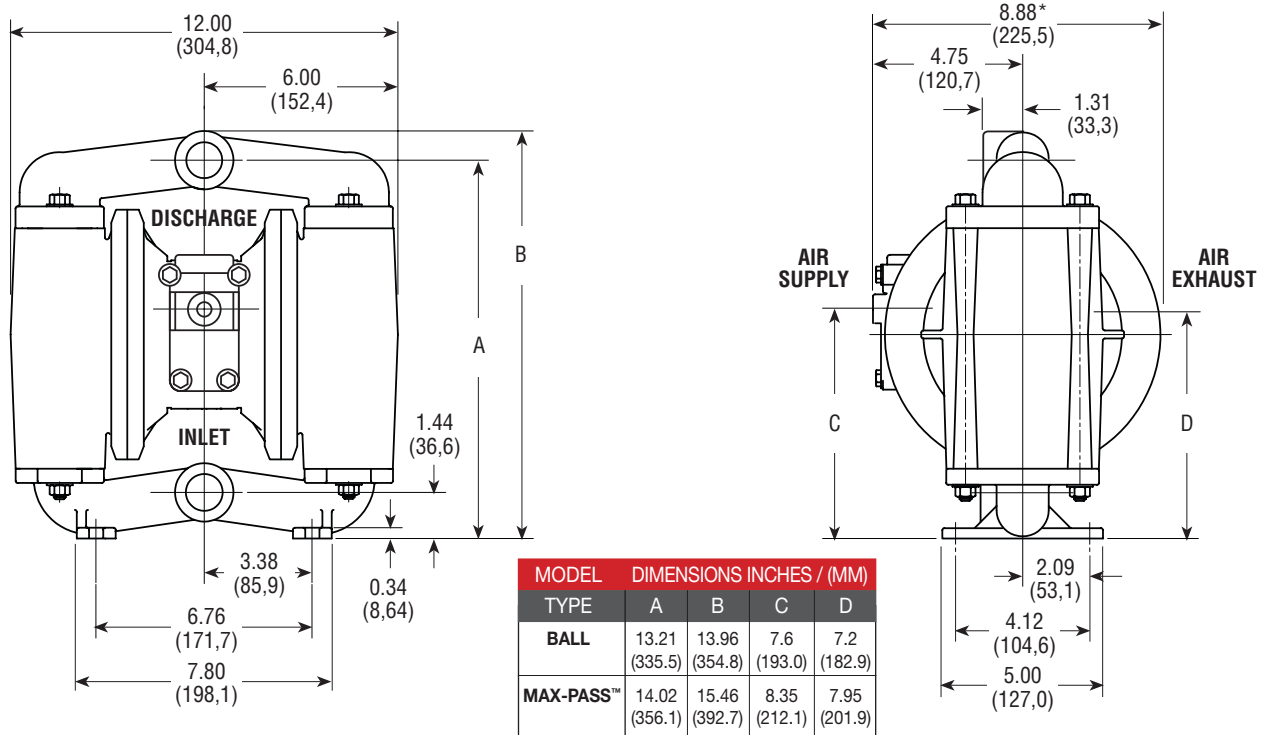

### 1" CLAMPED STYLE HEAVY DUTY PUMP (PLASTIC)

Dimensions in inches and (mm). For detailed dimensional drawings, please visit [www.all-flo.com](http://www.all-flo.com)

