

## 3" & 4" Engine Driven Trash Pumps



4" Engine Driven Trash Pump



3" Engine Driven Trash Pump

AMT Engine Driven Trash pumps are designed for applications which require high flow efficiency and solid handling capability. These pumps are constructed of heavy duty sand cast aluminum components featuring removeable/replaceable cast iron volutes, impellers and wearplates. Simple cleanout design permits easy removal of trash and debris without disconnecting hoses. Cast iron discharge port rotates in 90° increments. An electric start option is available on many models.

- **Cast Aluminum with Cast Iron Wearparts**
- **Viton®/Silicon Carbide Mechanical Seal & Buna-N O-Ring/Gasket**
- **3" & 4" Cast Iron Male Port Sizes with 90° Rotatable Discharge Port**
- **Self-Priming up to 20 Feet with Built-In Buna-N Check Valve**
- **Engine Options: Honda, Briggs & Stratton, Vanguard Gasoline or Yanmar Diesel Engines**
- **3" Models Featured in Heavy Duty Steel Roll Frame**
- **4" Models Feature Base, Rails and 16" Tires**
- **Maximum Solids Handling up to 2"**
- **Electric Start Option Available**
- **3" & 4" Models Include Front Cleanout with Cast Aluminum Handles**
- **Optional Wheel Kit Available**

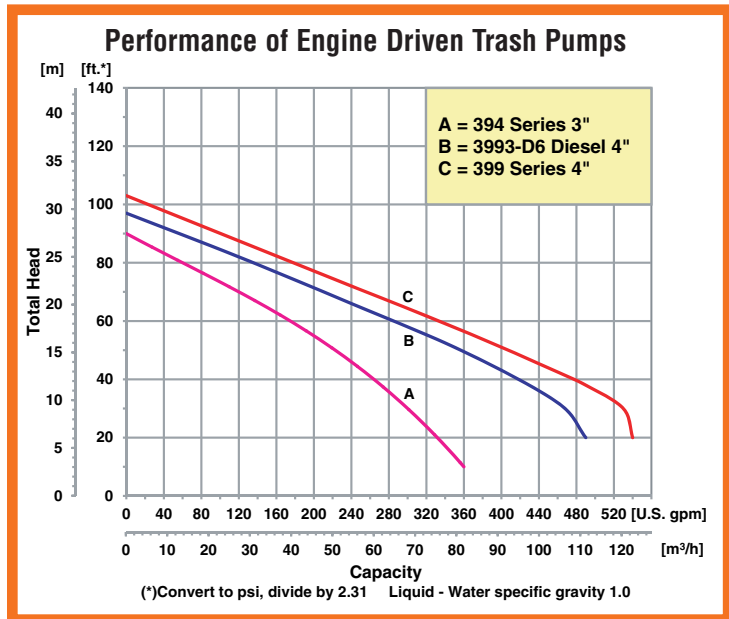

400 Spring Street • Royersford, PA 19468 USA

[www.amtpump.com](http://www.amtpump.com) • 888-amt-pump (268-7867)

For use with nonflammable liquids compatible with pump component materials. Viton® and Teflon® are registered trademarks of E. I. DuPont.

## 3" Trash Pumps

Model	Curve	Port	Driver	Seal	Run Time (Hours)	Tank Size (Gal/Ltr.)	Ship Wt. (Lbs.)
3941-96	A	3" NPT	B & S Vanguard▲	Viton® / SIC	1.3	0.95/3.6	145
3943-96	A	3" NPT	Honda OHV GX270▲	Viton® / SIC	2.5	1.40/5.3	160
3944-96	A	3" NPT	Honda GX270**▲	Viton® / SIC	2.5	1.40/5.3	185
3942-D6	A	3" NPT	Yanmar Diesel L100**▲	Viton® / SIC	2.7	1.43/5.4	205

Construction: Aluminum with Cast Iron Wearparts

Maximum Solids Handling Capacity: 1½" Diameter

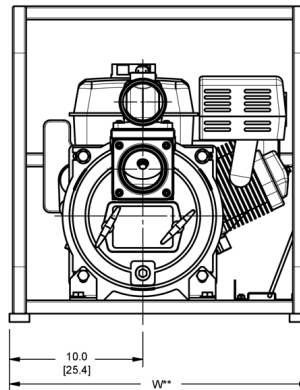
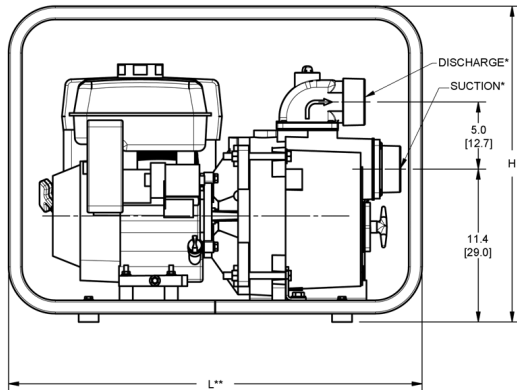

## 4" Trash Pumps

Model	Curve	Port	Driver	Seal	Run Time (Hours)	Tank Size (Gal/Ltr.)	Ship Wt. (Lbs.)
3993-D6	B	4" NPT	Yanmar Diesel L100**▲	Viton® / SIC	2.7	1.43/5.4	320
3993-96	C	4" NPT	B & S Vanguard**	Viton® / SIC	1.8	2.25/8.5	295
3994-96	C	4" NPT	Honda OHV GX390**▲	Viton® / SIC	2.5	1.60/6.1	300

Construction: Aluminum with Cast Iron Wearparts

Maximum Solids Handling Capacity: 2" Diameter

\*\* 12V DC Electric Start (Battery Not Included—Use BCI Group: U1 or U2 32 Amp Hour)

▲ Oil Alert Included

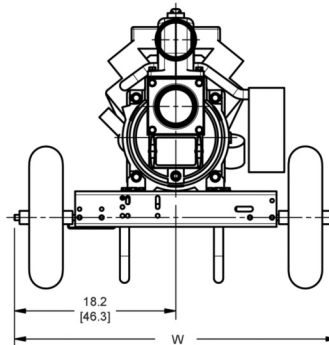
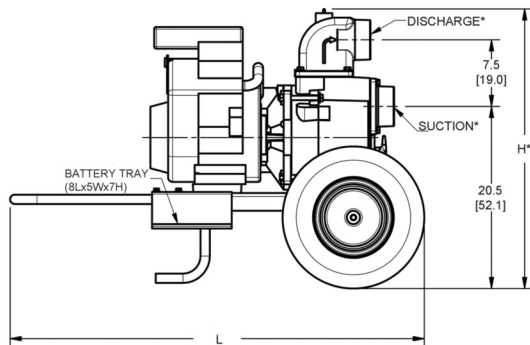

## Standard Features

- Cast Iron Male NPT Suction & Discharge Ports
- Viton®/Silicon Carbide Mechanical Seal
- Buna-N O-ring and Casing Seal
- Self-priming to 20 Feet with Built-in Buna Check Valve
- Stainless Steel Shaft Sleeve
- Steel Suction Strainer Included
- Cast Iron Replaceable Volute/Wearplate and Impeller
- Maximum Temperature 180° F
- Maximum Working Pressure 75 PSI
- 3" Models Featured in Heavy Duty Steel Roll Frame
- 4" Models Include Wheel Kit and Base Rails
- B & S Vanguard and Honda Engines are Overhead Valve (OHV) Designs with Low Oil Alert

## Optional Wheel Kit For Roll Frame Pumps

Model	Features	Ship Wt.
C402-90	Includes 10" semi-pneumatic tires on steel wheels with steel clamps and handles for universal mounting to frame.	25

Model	HP Class♦	SUC*	DIS*	L**	W**	H**
394X Series	8 HP	3	3	31.0 [78.7]	22.5 [57.2]	23.6 [60.0]
399X Series	10/13 HP	4	4	44.4 [112.7]	37.5 [95.2]	30.6 [77.7]

♦ HP Class represents market category and is not intended to define actual horsepower.

(\*) Standard NPT (Female) pipe thread.

(\*\*) This dimension may vary due to engine manufacturer's specifications.

NOTE: Dimensions are in inches (centimeters) and have a tolerance of ± 1/8".