

# MicroTron

## Series B

Chemical Metering Pump

***Digitally  
Accurate  
Speed  
Adjustment***

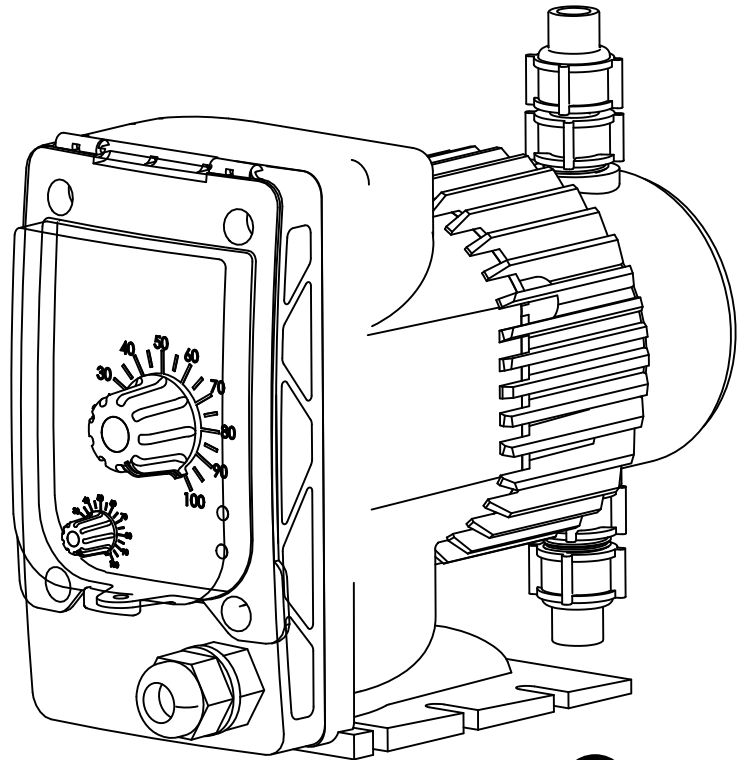

## Key Features

- Dual Output Adjustment
- NEMA 4X Style Enclosure
- Guided Double Ball Checks
- Circuit Voltage Protection
- Thermal Overload Protection
- Priming / Degassing Valve
- LED Indicating Lights
- Splash Cover Over Controls
- 2 Year Warranty

## Application

MicroTron Series B metering pumps provide reliable, economical chemical addition for a wide variety of applications.

Precise stroking speed is maintained with a digitally accurate speed adjustment. Metering accuracy is achieved with double ball guided checks. A NEMA 4X style housing allows for outdoor installations.

Series B pumps are available in outputs up to 55 GPD and 250 PSI. The manual stroke length and digital speed adjustment provides a wide turn down capability on all models.

# Build a Model

Model B \_ \_ \_ \_ \_ - \_ \_ \_ \_ \_

Build your model number by selecting one code from each step. Example: B130X1-PVC1

## STEP 1 OUTPUT (MAXIMUM)

115	15 GPD / 2.37 LPH	at	150 PSI (10.3 bar)
130	30 GPD / 4.70 LPH	at	110 PSI (7.5 bar)
155	55 GPD / 8.67 LPH	at	75 PSI (5.1 bar)
217	17 GPD / 2.60 LPH	at	250 PSI (17.2 bar)

## STEP 2 CONTROL OPTIONS

X	Standard
D	Dual Output 10-50 sph or 1-125 spm
E	External Pace
L	Limit Timer

## STEP 3 VOLTAGE

1	(Standard) 110 Volt USA Plug
2	230 Volt
3	230 Volt Specified Plug

## STEP 4 HEAD MATERIAL

P	Polypropylene
K	Kynar
V	PVC

## STEP 5 SEAT MATERIAL

V	Viton
F	Teflon
H	Hypalon

## STEP 6 CHECK BALL

C	Ceramic
S	Stainless

## STEP 7 CONNECTIONS

1	3/8" (9.525 mm) Tubing - 110 & 150 psi
2	1/4" (6.35 mm) Tubing - 250 psi
3	3/8" (9.525 mm) Tubing - 250 psi
P	1/4" (6.35 mm) MNPT Connections
V	3/8" (9.525 mm) Vinyl Suction Tubing - 110 or 250 psi

For other options, see Price List or consult factory.

# Accessories

Standard models include everything needed for immediate start-up: injection, foot and priming valve assemblies plus suction and discharge tubing.

# Specifications

## Electrical

- Input - 120 VAC or 230 VAC @ 50/60 Hz

## Operational

- Stroke length adjustment - 10-100%
- Stroke frequency - 1-125 strokes/minute for 15, 30 & 17 GPD; 1 - 160 strokes / min. for the 55 GPD

## Enclosure

Heavy duty NEMA 4X type high impact thermoplastic with clear lexan cover.

## Environment

- Ambient temperature 32° to 140°F (0 to 60°C)
- Relative humidity 0 to 100%

**Shipping Weight:** Approximately 10 lbs. (4.536 kg)

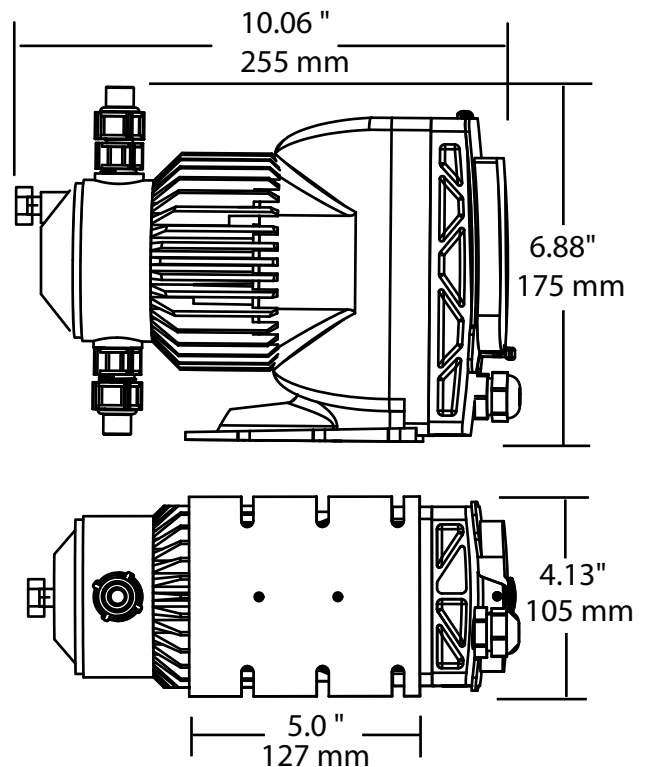

**Get the Advantage**



4700 Harold Abitz Dr  
Muskogee, OK 74403  
800-743-7431 phone  
888-686-6212 fax  
[www.advantagecontrols.com](http://www.advantagecontrols.com)