

SCOT

INSTALLATION INSTRUCTIONS TYPE 21 SHAFT SEAL

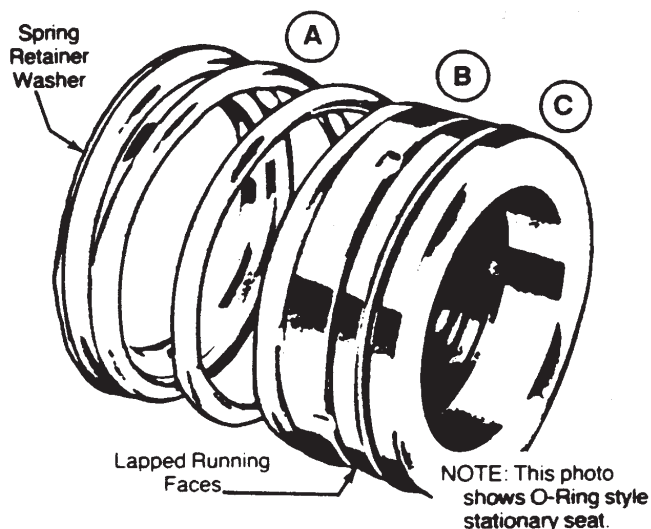

The seal assembly consists of these components:

- A SPRING
- B ROTARY SEAL HEAD
- C STATIONARY SEAT - May have an O-ring groove in seat (C) or a rubber cup seat (CC).

CAUTION: This seal is a precision product and should be handled accordingly. Be especially careful of the lapped sealing surface of the rotary washer and stationary seat.

THE SEAL IS SUPPLIED WITH A PACKET OF LUBRICANT.

LAPPED RUNNING FACES

The lapped running surfaces of the rotary seal head and stationary seat must be treated with care. KEEP CLEAN. DO NOT SCRATCH. Use a clean, soft cloth during installation. Protect the faces. Install both the seat and rotary square to the shaft. Check the stationary seat installation from behind the seal cavity for squareness.

STATIONARY SEAT INSTALLATION (C)

Clean the seal seat cavity of the adapter and lubricate.

Lubricate the seat O-ring or cup and press the stationary seat in seal cavity of the adapter squarely and evenly using an arbor press and the cardboard disc supplied with the seal. Be careful not to scratch or touch the lapped surface of stationary seat.

Inspect the face of the stationary seat to be certain there is no dirt on face. If there is any dirt or fingerprints on the face, wipe it off carefully with a soft cloth.

ROTARY SEAL HEAD INSTALLATION (B)

Clean, polish and lubricate the shaft (or shaft sleeve).

Check lapped faces on the stationary seat and rotary seal head. Be certain no dirt is on either face. Lubricate lightly.

Slide the rotary seal head on the shaft with the carbon rotating ring facing the stationary seat. Press the drive band until the head seats firmly against the seat. Install spring (and spring retainer washer if used). Install impeller which will compress the spring to proper length assuring correct pressure on the lapped faces.

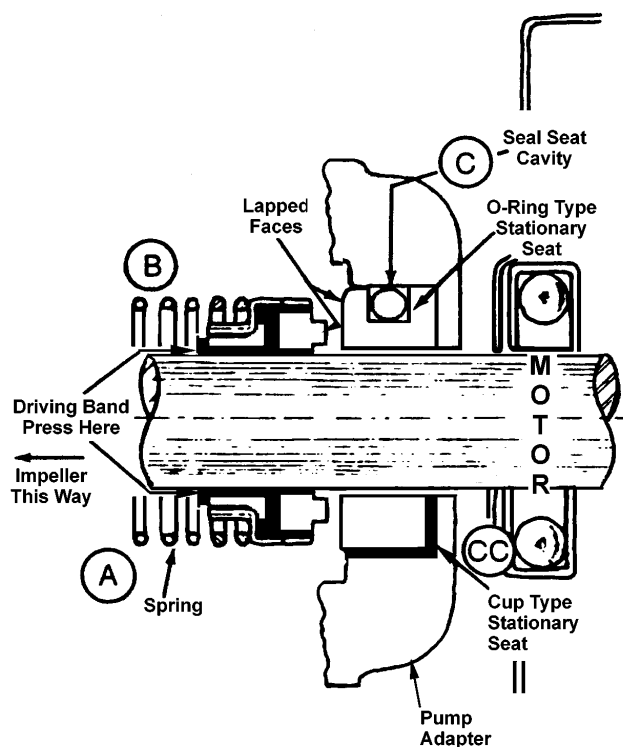

CAUTION: Never operate the lapped running faces dry. The liquid being handled ensures proper lubrication.

In some cases a short period of operation is required to clear up slight leakage.

NOTE: The lubricant supplied with the seal is the only approved lubricant. DO NOT USE OTHER LUBRICATING LIQUIDS!

HOME OFFICE			
• Cedarburg, WI 53012	• P.O. Box 286	• 262-377-7000	• FAX 262-377-7330
FACTORY BRANCHES			
• Irvine, CA 92614	• 1881 Kettering	• 949-756-8076	• FAX 949-756-9480
• Ft. Lauderdale, FL 33315	• 77 SW 20th Street	• 954-524-6776	• FAX 954-764-3361

SCOT DIVISION OF
ARDOX CORP.

61.000.172B

JANUARY 2000

SUCCESSFUL SEAL INSTALLATION

1. **Read entire installation procedure** before beginning installation.
2. **Handle components carefully.** Careless handling of the critical seal components may result in chipping, cracking or breakage.
3. **Do not touch sealing areas.** The sealing faces, O-rings, wedges, and bellows must kept perfectly clean. Even a fingerprint can cause a seal to leak. Primary and secondary sealing areas must be kept clean and undamaged to ensure a proper seal. Rubber gaskets tear easily when handled carelessly.
4. Make sure that the **shaft or sleeve is free of burrs, nicks, grooves, and sharp edges.**
5. **Bleed all trapped gases from the seal cavity before start-up,** otherwise the seal cavity may vapor lock and burn the seal.
6. **All valves must be open on the suction side of the pump** so that the seal is assured of a positive flow of liquid at all times. Failure to do so will also cause the seal to burn.