

1/2" HEAVY DUTY BOLTED STYLE DRUM PUMP



1/2" HEAVY DUTY BOLTED STYLE DRUM PUMP

Engineered for maximum fluid and chemical compatibility. Heavy duty, non-metallic air section ensures stall free and freeze free operation. Rugged valve system allows operation under a variety of conditions, ranging from clean fluids to slurries, to small solids. Bolted design provides ease of maintenance and leak free operation. Available in a variety of materials and options.

- Suitable for Clean Fluids, Slurries or up to 1/8" Solids
- Includes 40" Suction Tube and Bung Adaptor
- Solids Handling Options Available
- Heavy Duty Air Valve
- Muffler Included

SPECIFICATIONS

Dimension	
Physical Dimensions	See Drawing Page 74
Air Inlet	1/4"
Liquid Inlet	1/2"
Liquid Outlet	1/2"
Weight	See Product Tables
Performance	
Maximum Flow	17 gpm (64.6 lpm)
Maximum Air Pressure	120 psi (8.2 bar)
Maximum Solids	1/8" (3.2 mm)
Max Suction Lift Dry	15 ft (4.5 m)
Max Suction Lift Wet	26 ft (7.9 m)
Max Suction Lift Dry with PTFE	10 ft (3 m)
Max Temperature	See Product Tables
Noise Level (with muffler)	83 dBA
Displacement Per Stroke	0.025 Gallons (0.095 l)



PERFORMANCE CURVE (Based on water-flooded suction)

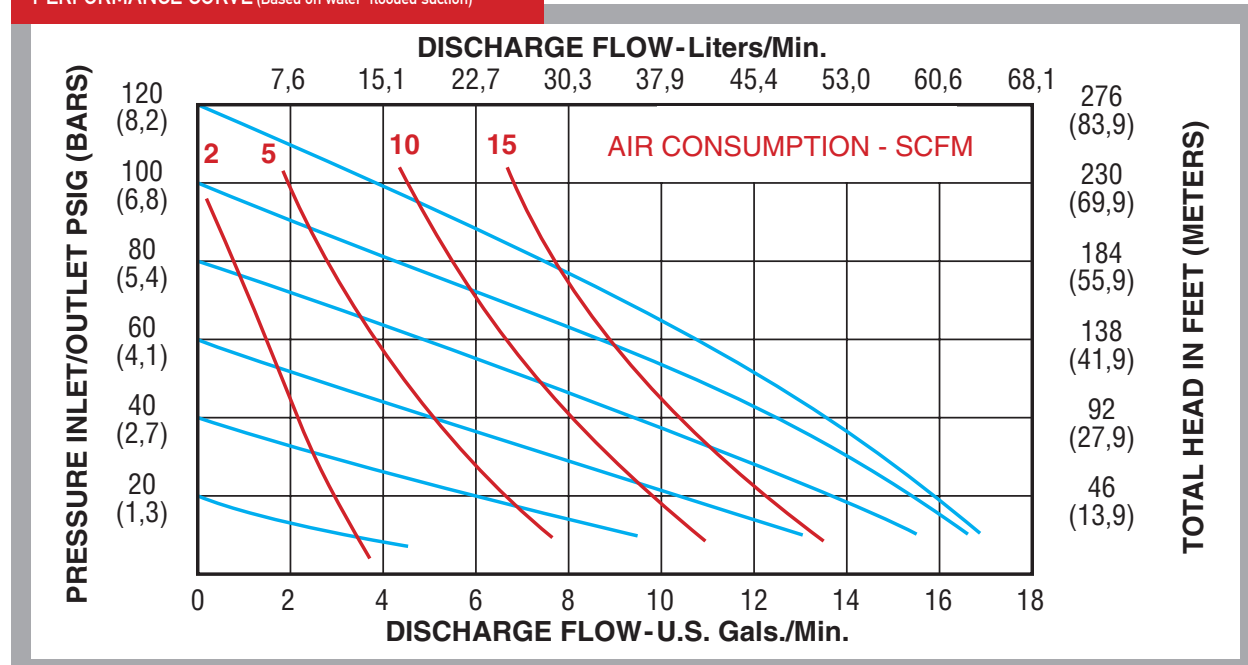

1/2"

1/2" - ALUMINUM - General purpose pump, suitable for water, oils, most solvents, and most paints. Please consult chemical compatibility tables or www.all-flo.com for your particular application.

PART NUMBER	DIAPHRAGM MATERIAL	VALVE/BALL MATERIAL	VALVE SEAT MATERIAL	O-RING MATERIAL	FASTENER MATERIAL	WEIGHT LBS (KG)	MAX TEMPERATURE °F (°C)	DIMENSIONAL DIAGRAM	CONNECT TYPE
ABD-05	Geolast®	Geolast®	Polypropylene	Nitrile	SS	17 (7.7)	180 (82)	Pg. 74	NPT (BSP)
ABD-05-B2	Geolast®	PTFE	Polypropylene	Nitrile	SS	17 (7.7)	180 (82)	Pg. 74	NPT (BSP)
ATD-05	PTFE	PTFE	Nylon	PTFE	SS	17 (7.7)	212 (100)	Pg. 74	NPT (BSP)
AED-05	Santoprene®	Santoprene®	Polypropylene	EPDM	SS	17 (7.7)	212 (100)	Pg. 74	NPT (BSP)
AVD-05	Viton®	Viton®	Nylon	Viton®	SS	17 (7.7)	212 (100)	Pg. 74	NPT (BSP)

1/2" - 316 SS - Corrosion resistant steel, suitable for nitric acid, chlorinated solvents, caustics and marine applications. Please consult chemical compatibility tables or www.all-flo.com for your particular application.

PART NUMBER	DIAPHRAGM MATERIAL	VALVE/BALL MATERIAL	VALVE SEAT MATERIAL	O-RING MATERIAL	FASTENER MATERIAL	WEIGHT LBS (KG)	MAX TEMPERATURE °F (°C)	DIMENSIONAL DIAGRAM	CONNECT TYPE
SBD-05	Geolast®	Geolast®	SS	Nitrile	SS	26 (11.8)	180 (82)	Pg. 74	NPT (BSP)
SPD-05	PTFE	PTFE	SS	PTFE	SS	26 (11.8)	212 (100)	Pg. 74	NPT (BSP)
SED-05	Santoprene®	Santoprene®	SS	EPDM	SS	26 (11.8)	212 (100)	Pg. 74	NPT (BSP)
SVD-05	Viton®	Viton®	SS	Viton®	SS	26 (11.8)	212 (100)	Pg. 74	NPT (BSP)

1/2" - POLYPROPYLENE - A non-metallic material, suitable for water, caustics, soap solutions, mild acids and general purpose applications. Please consult chemical compatibility tables or www.all-flo.com for your particular application.

PART NUMBER	DIAPHRAGM MATERIAL	VALVE/BALL MATERIAL	VALVE SEAT MATERIAL	O-RING MATERIAL	FASTENER MATERIAL	WEIGHT LBS (KG)	MAX TEMPERATURE °F (°C)	DIMENSIONAL DIAGRAM	CONNECT TYPE
PBD-05	Geolast®	Geolast®	Polypropylene	Nitrile	SS	16 (7.3)	150 (66)	Pg. 74	NPT (BSP)
PTD-05	PTFE	PTFE	Polypropylene	PTFE	SS	16 (7.3)	150 (66)	Pg. 74	NPT (BSP)
PED-05	Santoprene®	Santoprene®	Polypropylene	EPDM	SS	16 (7.3)	150 (66)	Pg. 74	NPT (BSP)
PVD-05	Viton®	Viton®	Polypropylene	Viton®	SS	16 (7.3)	150 (66)	Pg. 74	NPT (BSP)

1/2" - PVDF - Polyvinylidene Fluoride suitable in applications requiring the highest purity, strength, and resistance to solvents, acids, and bases. Please consult chemical compatibility tables or www.all-flo.com for your particular application.

PART NUMBER	DIAPHRAGM MATERIAL	VALVE/BALL MATERIAL	VALVE SEAT MATERIAL	O-RING MATERIAL	FASTENER MATERIAL	WEIGHT LBS (KG)	MAX TEMPERATURE °F (°C)	DIMENSIONAL DIAGRAM	CONNECT TYPE
KTD-05	PTFE	PTFE	PVDF	PTFE	SS	12 (5.4)	200 (93)	Pg. 74	NPT (BSP)
KED-05	Santoprene®	Santoprene®	PVDF	EPDM	SS	12 (5.4)	200 (93)	Pg. 74	NPT (BSP)
KVD-05	Viton®	Viton®	PVDF	Viton®	SS	12 (5.4)	200 (93)	Pg. 74	NPT (BSP)

1/2" - CONDUCTIVE NYLON - Stainless steel filled nylon, suitable for most solvents and alcohols. Grounding lugs provided with pump. Please consult chemical compatibility tables or www.all-flo.com for your particular application.

PART NUMBER	DIAPHRAGM MATERIAL	VALVE/BALL MATERIAL	VALVE SEAT MATERIAL	O-RING MATERIAL	FASTENER MATERIAL	WEIGHT LBS (KG)	MAX TEMPERATURE °F (°C)	DIMENSIONAL DIAGRAM	CONNECT TYPE
CND-05	Geolast®	Nitrile	SS	Nitrile	SS	19 (8.6)	150 (66)	Pg. 74	NPT (BSP)
CBD-05	Geolast®	Geolast®	SS	Nitrile	SS	19 (8.6)	150 (66)	Pg. 74	NPT (BSP)
CTD-05	PTFE	PTFE	SS	PTFE	SS	19 (8.6)	150 (66)	Pg. 74	NPT (BSP)
CVD-05	Viton®	Viton®	SS	Viton®	SS	19 (8.6)	150 (66)	Pg. 74	NPT (BSP)

AVAILABLE OPTIONS - Each pump can be configured to suit a particular application. Please see the options section for detailed product information on the following available options.

AIR VALVE OPTIONS	SEE PAGE 67	
CYCLE COUNT VALVE	SOLENOID ADAPTOR VALVE	
BALL VALVE OPTIONS	SEE PAGE 67	
GEOLAST®	PTFE	
SANTOPRENE®	STAINLESS STEEL	
WETTED CHAMBER FINISH OPTIONS	SEE PAGE 67	
HARD COAT ANODIZING	PASSIVATED & ELECTROPOLISHED	
HARDWARE OPTIONS	SEE PAGE 67	
PTFE COATED HARDWARE		
O-RINGS	SEE PAGE 67	
PTFE O-RINGS	NITRILE O-RINGS	
EPDM O-RINGS	VITON® O-RINGS	
PORTING OPTIONS	SEE PAGE 68	
DUAL DISCHARGE / SUCTION	ALL PORTS OPEN	
SUCTION / DOWN		
VALVE SEAT OPTIONS	SEE PAGE 68	
POLYPROPYLENE	NYLON	
PVDF	STAINLESS STEEL	
MAX PASS VALVE SOLIDS HANDLING OPTIONS	SEE PAGE 68	
NITRILE	EPDM	FDA VITON®
MISC. AND SPECIAL OPTIONS	SEE PAGE 68	
ATEX CATEGORY 2		

AVAILABLE ACCESSORIES - Please see the accessories section for detailed product information on the following available accessories.

AIR	SEE PAGE
FILTER / REGULATOR / GAUGE	60
SOLENOID VALVES	60
AIR FLOW CONTROL VALVES	60
NEEDLE VALVE	60
LIQUID	
SUCTION STRAINER	61
FILTER HOUSING	61
PUMP	
PREMIUM MUFFLER	63
METAL MUFFLER	63
GROUNDING LUG	64



METALLIC
All of our 1/2" metallic pumps have a non-metallic center section. This design concept ensures maximum chemical compatibility while protecting from environmental corrosion.



CONDUCTIVE NYLON
Our conductive nylon pumps achieve desired chemical compatibility while providing grounding capability for safe operation.



NON-METALLIC
Our non-metallic pumps are available in a variety of materials and porting options, allowing for maximum application installation.

1/2" BOLTED STYLE HEAVY DUTY PUMP (PLASTIC)

Dimensions in inches and (mm). For detailed dimensional drawings, please visit www.all-flo.com

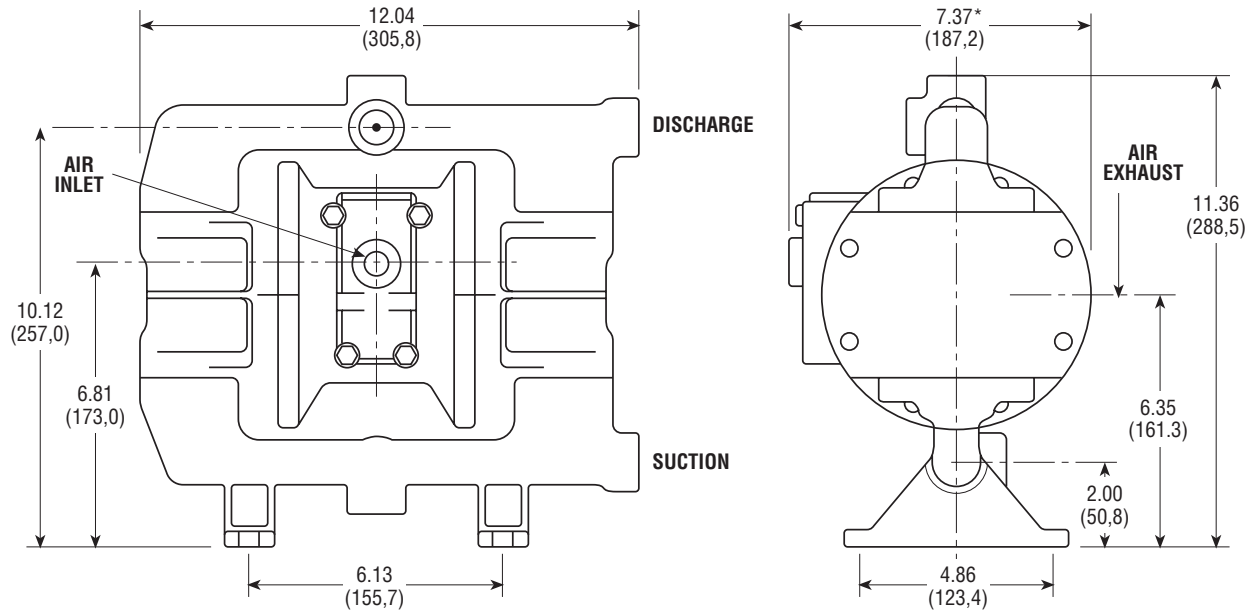

1/2" BOLTED STYLE HEAVY DUTY PUMP (METALLIC)

Dimensions in inches and (mm). For detailed dimensional drawings, please visit www.all-flo.com

