

INSTALLATION, OPERATION &
MAINTENANCE MANUAL
FOR
SERIES 460
OSD ANSI PROCESS END
SUCTION PUMP

27 MAY 2004
Copyright © 2004 American-Marsh Pumps

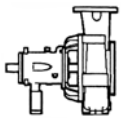

CONTENTS

Page #

SAFETY CONSIDERATIONS 5

DANGER 5

WARNING 5

CAUTION..... 5

PUMP IDENTIFICATION 6

MANUFACTURER 6

TYPE OF PUMP 6

DATE OF MANUFACTURE 6

INSTALLATION, OPERATION & MAINTENANCE MANUAL IDENTIFICATION 6

NAMEPLATE INFORMATION..... 6

FIELD OF APPLICATION 7

STANDARD OSD ANSI B73.1M 7

OSD LOW FLO ANSI B73.1M..... 7

SAFETY CONSIDERATIONS 8

WARRANTY 10

GENERAL INSTRUCTIONS..... 10

HANDLING AND TRANSPORT 10

METHOD OF TRANSPORT 10

INSTALLATION 10

STORAGE..... 10

SHORT-TERM STORAGE 10

LONG-TERM STORAGE..... 11

INSTALLATION & ALIGNMENT 11

FACTORY PRELIMINARY ALIGNMENT PROCEDURE..... 11

RECOMMENDED PROCEDURE FOR BASE PLATE INSTALLATION & FINAL FIELD ALIGNMENT 12

NEW GROUTED BASE PLATES..... 12

EXISTING GROUTED BASE PLATES..... 13

PIPING CONNECTION – SUCTION & DISCHARGE 13

SUCTION PIPING..... 13

DISCHARGE PIPING 14

PUMP AND SHAFT ALIGNMENT CHECK..... 14

MECHANICAL SEAL 14

PACKING..... 15

PIPING CONNECTION –SEAL/PACKING SUPPORT SYSTEM 15

PIPING CONNECTION –BEARING HOUSING COOLING SYSTEM 15

PIPING CONNECTION – SUPPORT LEG COOLING FOR CENTERLINE MOUNTING OPTION 16

PIPING CONNECTION – HEATING/COOLING FLUID FOR JACKETED COVER/CASING 16

PIPING CONNECTION –OIL MIST LUBRICATION SYSTEM 16

COUPLING 17

PUMP OPERATION 17

ROTATION CHECK..... 17

PRE START-UP CHECKS..... 17

ENSURING PROPER NPSH_A 17

MINIMUM FLOW 17

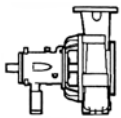

STARTING THE PUMP AND ADJUSTING FLOW 18

OPERATION IN SUB-FREEZING CONDITIONS 19

SHUTDOWN CONSIDERATIONS 19

TROUBLESHOOTING 19

MAINTENANCE..... 24

 PREVENTIVE MAINTENANCE..... 24

 NEED FOR MAINTENANCE RECORDS 24

 NEED FOR CLEANLINESS..... 24

 DISASSEMBLY 24

 CLEANING/INSPECTION 26

 CRITICAL MEASUREMENT AND TOLERANCES..... 26

 ASSEMBLY 27

 POWER END ASSEMBLY 28

BEARING INSTALLATION 28

LIP SEALS 30

LABYRINTH SEALS 30

MAGNETIC SEALS 30

BEARING CARRIER/POWER END ASSEMBLY..... 30

 WET END ASSEMBLY 30

CARTRIDGE MECHANICAL SEALS 30

COMPONENT TYPE MECHANICAL SEAL 31

PACKING WITH SPLIT GLAND 31

BEARING LUBRICATION..... 34

 REINSTALLATION 36

SPARE PARTS..... 36

 RECOMMENDED SPARE PARTS – STANDARD OSD PUMP 36

 HOW TO ORDER SPARE PARTS 36

APPENDIX A 40

 CRITICAL MEASUREMENTS AND TOLERANCES FOR MAXIMIZING MTBPM 40

PARAMETERS THAT SHOULD BE CHECKED BY USERS..... 40

ADDITIONAL PARAMETERS CHECKS BY AMERICAN-MARSH 40

SHAFT 41

IMPELLER BALANCING 41

BEARING HOUSING 41

POWER FRAME ASSEMBLY 41

SEAL CHAMBER..... 42

COMPLETE PUMP..... 42

 SPECIAL PARAMETERS CHECKED BY AMERICAN-MASH 43

SHAFT – MAXIMUM ROUGHNESS AT SEAL CHAMBER 43

BEARING HOUSING – BORE CONCENTRICITY..... 43

COMPLETE PUMP – DYNAMIC SHAFT DEFLECTION 43

APPENDIX B 44

 INSTALLATION/CLEARANCE SETTING FOR REVERSE VANE IMPELLER 44

APPENDIX C 45

 INSTALLATION/CLEARANCE SETTING FOR FRONT VANE SEMI-OPEN IMPELLER 45

APPENDIX D 47

 REMOVAL/INSTALLATION OF SEALS WITH FMI SEAL CHAMBER 47

 AMERICAN-MARSH OSD MAINTENANCE INSTRUCTIONS BEARING HOUSING OIL SEALS (LABYRINTH TYPE)

 INPRO/SEAL® VBXX BEARING ISOLATORS 48

APPENDIX F..... 50

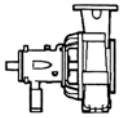

ALLOWABLE NOZZLE LOADS OSD PUMPS (ASME B73.1M)..... 50

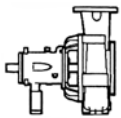

SAFETY CONSIDERATIONS

The American-Marsh OSD process pump has been designed and manufactured for safe operation. In order to ensure safe operation, it is very important that this manual be read in its entirety prior to installing or operating the pump. American-Marsh Pumps shall not be liable for physical injury, damage or delays caused by a failure to observe the instructions for installation, operation and maintenance contained in this manual.

Remember that every pump has the potential to be dangerous, because of the following factors:

- parts are rotating at high speeds
- high pressures may be present
- high temperatures may be present
- highly corrosive and/or toxic chemicals may be present

Paying constant attention to safety is always extremely important. However, there are often situations that require special attention. These situations are indicated throughout this book by the following symbols:



DANGER - Immediate hazards which WILL result in severe personal injury or death.



WARNING – Hazards or unsafe practices which COULD result in severe personal injury or death.



CAUTION – Hazards or unsafe practices which COULD result in minor personal injury or product or property damage.

Maximum Lifting Speed: 15 feet/second.

If in a climate where the fluid in the casing could freeze, never leave liquid in the pump casing. Drain the casing completely. During winter months and cold weather, the liquid could freeze and damage the pump casing.
ENGINEERED PROCESS GROUP

Do not run the equipment dry or start the pump without the proper prime (casing flooded).

Do not exceed the Maximum Design Pressure (MDP) at the temperature shown on the nameplate. See figure 2, page 8 for general pressure versus temperature ratings of common alloys.

Never operate the pump for more than a short interval with the discharge valve closed. The length of the interval depends on several factors including the nature of the fluid pumped and its temperature. Contact American-Marsh Engineering for additional support if required.

Never operate the pump with a closed suction valve.

Excessive pump noise or vibration may indicate a dangerous operating condition. The pump must be shutdown immediately.

Do not operate the pump for an extended period of time below the recommended minimum flow. See figure 14, page 18.

The pump shaft MUST turn clockwise when viewed from the motor end. It is absolutely essential that the rotation of the motor be checked before installation of the coupling spacer and starting the pump. Incorrect rotation of the pump for even a short period of time can unscrew the impeller, which can cause severe damage.

If the liquid is hazardous, take all necessary precautions to avoid damage and injury before emptying the pump casing.

Residual liquid may be found in the pump casing, head and suction line. Take the necessary precautions if the liquid is hazardous, flammable, corrosive, poisonous, infected, etc.

Always lockout power to the driver before performing pump maintenance.

Never operate the pump without the coupling guard and all other safety devices correctly installed.

Do not apply heat to disassemble the pump or to remove the impeller. Entrapped liquid could cause an explosion.

If any external leaks are found while pumping hazardous product, immediately stop operations and repair.

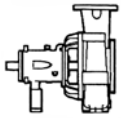

PUMP IDENTIFICATION

MANUFACTURER

American-Marsh Pumps
185 Progress Road
Collierville, TN 38017
United States of America

TYPE OF PUMP

The American-Marsh OSD chemical process pump is a horizontal, end suction, single stage, centerline

discharge, centrifugal pump. It is an "ANSI" standard pump, which means it conforms to the ASME B73.1M ANSI standard.

DATE OF MANUFACTURE

The date of manufacture is indicated on the pump data plate.

INSTALLATION, OPERATION & MAINTENANCE MANUAL IDENTIFICATION

Prepared: May, 2004 Edition: 01
Revision: Date of Revision:

NAMEPLATE INFORMATION

AMERICAN-MARSH PUMPS			
EQUIP NO.			
SIZE			
ALLOY	BASE		
SEAL	TYPE		
SEAL CODE			
CAPACITY	TDH		
RPM	MDP		
TEMP	SG	V	
SERIAL NO.	CE		

FIGURE 1 – Pump Data Plate

- EQUIP NO. : Tag information supplied by end user.
- SIZE : Size designation of pump (2L3x4-10 OSD)
- ALLOY : Construction of pump. Casing Material / Impeller Material (DS/DS).
- BASE : ANSI base designation.
- SEAL : Seal manufacturer (AMP, JC, etc).
- TYPE : Seal type (810, 820, 1, 21, 442, etc.).
- SEAL CODE : Material construction of seal (C20/E1 - X74/E1 - S316 - S316).
- CAPACITY : Rated capacity of pump.
- TDH : Rated Total Dynamic Head of pump.
- RPM : Speed of pump.
- MDP : Maximum design pressure of pump at 100 degrees Fahrenheit.
- TEMP : Temperature of pumped fluid.
- SG : Specific Gravity of pumped fluid.
- V : Viscosity of pumped fluid.
- SERIAL NUMBER : Serial Number of pump unit (issued by Production Control).
- CE : Location where built.

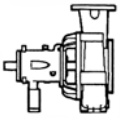

FIELD OF APPLICATION

STANDARD OSD ANSI B73.1M

The advanced design and precision manufacture of the rugged, heavy-duty OSD chemical service pump significantly enhances bearing and seal life, thereby extending mean time between planned maintenance (MTBPM). Its exclusive features provide significant performance benefits for petroleum and chemical pump users. Most notable among these are:

1. The exclusive reverse vane impeller offers important performance-enhancing, maintenance-reducing advantages.
2. The exclusive external micro-millimeter shaft adjustment provides dead accurate setting of impeller clearance in seconds.
3. The OSD power frame and full family of seal chambers are building blocks for improved MTBPM.

OSD LOW FLO ANSI B73.1M

The American-Marsh OSD Lo-Flo Pump has a special design casing and impeller which allows it to work very reliably at low flows. The pump has an impeller with radial vanes that twist around the hub, and a circular, concentric casing. This design ensures that, at low flows, no significant hydraulic radial forces are transmitted to the shaft. Minimum flow on this pump is "Minimum Thermal Flow". This is defined as the minimum flow that will not cause an excessive temperature rise.

WARNING

Do not operate the Lo-Flo pump below Minimum Thermal Flow, as this could cause an excessive temperature rise. Contact an American-Marsh Sales Engineer for determination of Minimum Thermal flow.

Only the impeller and casing are special, all other parts are standard OSD parts. Note: The adapter on the 13 inch pump is the standard adapter but with 16 holes drilled in it for attachment to the casing.

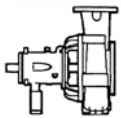

SAFETY CONSIDERATIONS

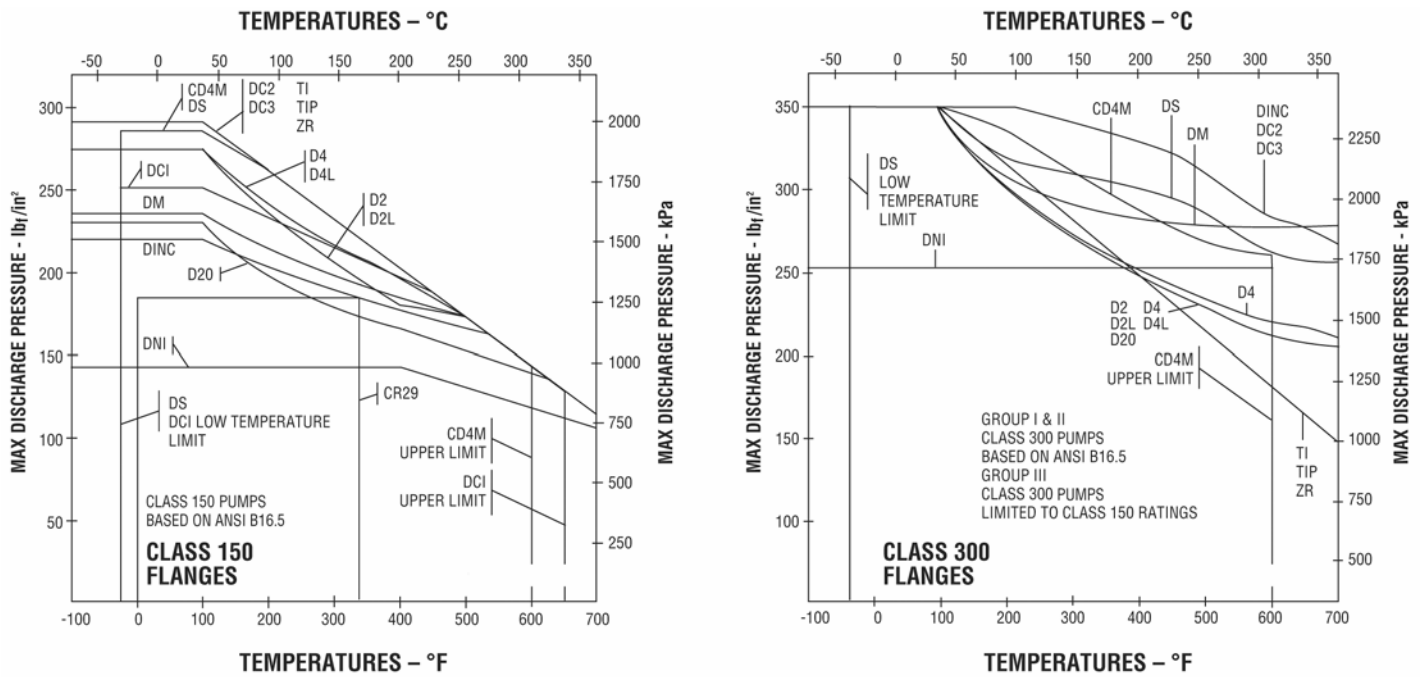

FIGURE 2 – Pressure-Temperature Limits By Alloy

Designation	Symbol	ACI Designation	Equivalent Wrought Designation	ASTM Specification
Ductile Iron	DCI	None	None	A395
High Chrome Iron	CR28	None	None	A532 class III
High Chrome Iron	CR29	None	None	None
High Chrome Iron	CR35	None	None	None
Carbon Steel	DS	None	Carbon Steel	A216, Gr. WCB
CF8	D2	CF8	304	A744, Gr. CF8
CF3	D2L	CF3	304L	A744, Gr. CF3
CF8M	D4	CF8M	316	A744, Gr. CF8M
CF3M	D4L	CF3M	316L	A744, Gr. CF3M
Ferralium®	CD4M	Cd4MCu	Ferralium®	A744, Gr. Cd4Mcu
Alloy 20	D20	CN7M	Alloy 20	A744, Gr. CN7M
Inconel® 600	DIN	CY40	Inconel® 600	A744, Gr. CY40
Monel® 400	DM	M351	Monel® 400	A744, Gr. M351
Nickel	DNI	CZ100	Nickel 200	A744, Gr. CZ100
Chlorimet 2	DC2	N7M	Hastelloy® B	A744, Gr. N7M
Chlorimet 3	DC3	CW6M	Hastelloy® C	A744, Gr. CW6M
Titanium	Ti	None	Titanium	B367, Gr. C3
Titanium-Pd	Ti-Pd	None	Titanium-Pd	B367, Gr. C8A
Zirconium	Zr	None	Zirconium	B367, Gr. 702C

®Ferralium is a registered trademark of Langley Alloys. ®Hastelloy is a registered trademark of Haynes International. ®Inconel and Monel are registered trademarks of International Nickel Co. Inc.

FIGURE 3 – Alloy Cross Reference Chart

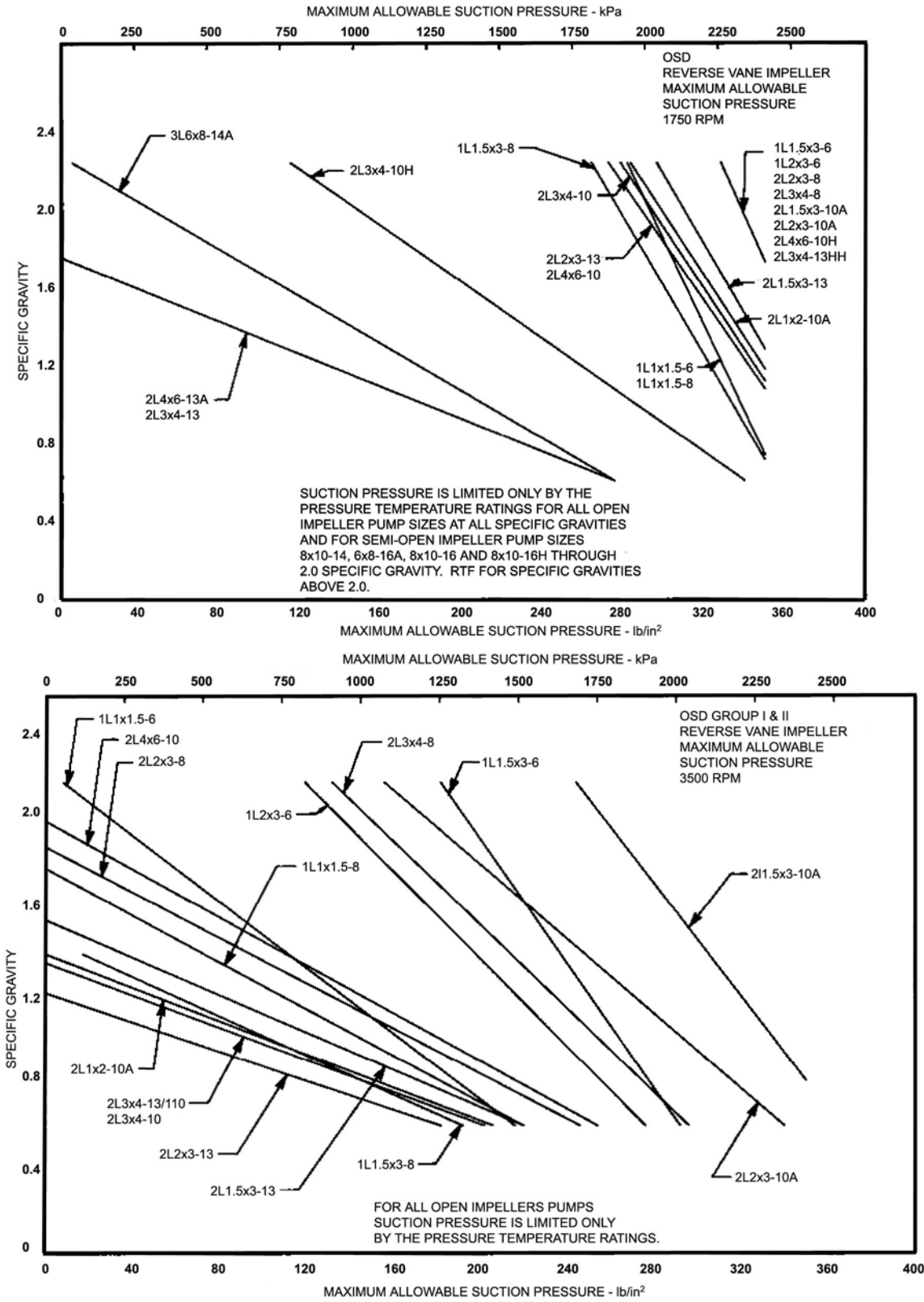
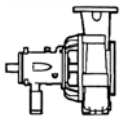
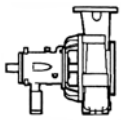

FIGURE 4 – Maximum Allowable Suction Pressures



In case of doubt, contact the manufacturer.

WARRANTY

American-Marsh Pumps guarantees that only high quality materials are used in the construction of our pumps and that machining and assembly are carried out to high standards.

The pumps are guaranteed against defective materials and/or faulty craftsmanship for a period of one year from the date of shipment unless specifically stated otherwise.

Replacement of parts or of the pump itself can only be carried out after careful examination of the pump by qualified personnel.

The warranty is not valid if third parties have tampered with the pump.

This warranty does not cover parts subject to deterioration or wear and tear (mechanical seals, pressure and vacuum gauges, rubber or plastic items, bearings, etc.) or damage caused by misuse or improper handling of the pump by the end user.

Parts replaced under warranty become the property of American-Marsh Pumps.

Contact the American-Marsh Pumps' factory:

American-Marsh Pumps
185 Progress Road
Collierville, TN 38017
United States Of America

Phone: (901) 860-2300
Fax: (901) 860-2323
www.american-marsh.com

GENERAL INSTRUCTIONS

The pump and motor unit must be examined upon arrival to ascertain any damage caused during shipment. If damaged immediately notify the carrier and/or the sender. Check that the goods correspond exactly to the description on the shipping documents and report any differences as soon as possible to the sender. Always quote the pump type and serial number stamped on the data plate.

The pumps must be used only for applications for which the manufacturers have specified:

- ❖ **The construction materials**
- ❖ **The operating conditions (flow, pressure, temperature, etc.)**
- ❖ **The field of application**

HANDLING AND TRANSPORT

METHOD OF TRANSPORT

The pump must be transported in the horizontal position

INSTALLATION

During installation and maintenance, all components must be handled and transported securely by using suitable slings. Handling must be carried out by specialized personnel to avoid damage to the pump and persons. The lifting rings attached to various

CAUTION

components should be used exclusively to lift the components for which they have been supplied.

Maximum lifting speed: 15 feet/second

STORAGE

SHORT-TERM STORAGE

Normal packaging is designed to protect the pump during shipment and for dry, indoor storage for up to two months or less. The procedure followed for this short-term storage is summarized below:

Standard Protection for Shipment :

- a. Loose unmounted items, including, but not limited to, oilers, packing, coupling spacers, stilts, and mechanical seals are packaged in a water proof plastic bag and placed under the coupling guard. Larger items are cartoned and metal banded to the base plate. For pumps not mounted on a base plate, the bag and/or carton is placed inside the shipping carton. All parts bags and cartons are identified with the American-Marsh sales order number, the customer purchase order number, and the pump item number (if applicable).
- b. Inner surfaces of the bearing housing, shaft (area through bearing housing), and bearings are coated with Cortec VCI-329 rust inhibitor, or equal.

Note: Bearing housings are not filled with oil prior to shipment.

- c. Regreasable bearings are packed with grease (Royal Purple NLGI#2).
- d. After a performance test, if required, the pump is tipped on the suction flange for drainage (some residual water may remain in the casing). Then, internal surfaces of ferrous casings, covers,

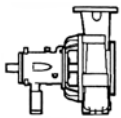

- flange faces, and the impeller surface are sprayed with Calgon Vestal Labs RP-743m, or equal. Exposed shafts are taped with Polywrap.
- e. Flange faces are protected with plastic covers secured with plastic drive bolts. 3/16 in (7.8 mm) steel or 1/4 in (6.3 mm) wood covers with rubber gaskets, steel bolts, and nuts are available at extra cost.
 - f. All assemblies are bolted to a wood skid which confines the assembly within the perimeter of the skid.
 - g. Assemblies with special paint are protected with a plastic wrap.
 - h. Group 1 and Group 2 bare pumps, when not mounted on base plates, are packed in hard paper cartons mounted on wood skids.
 - i. Group 3 bare pumps, when not mounted on base plates, are bolted to wood skids.
 - j. All pump assemblies utilizing polycrystalline base plates are mounted on wood skids.
 - k. All assemblies having external piping (seal flush and cooling water plans), etc. are packaged and braced to withstand normal handling during shipment. In some cases components may be disassembled for shipment. The pump must be stored in a covered, dry location.

LONG-TERM STORAGE

Long-term storage is defined as more than two months, but less than 12 months. The procedure American-Marsh follows for long-term storage of pumps is given below. These procedures are in addition to the short-term procedure.

Solid wood skids are utilized. Holes are drilled in the skid to accommodate the anchor bolt holes in the base plate, or the casing and bearing housing feet holes on assemblies less base plate. Tackwrap sheeting is then placed on top of the skid and the pump assembly is placed on top of the Tackwrap. Metal bolts with washers and rubber bushings are inserted through the skid, the Tackwrap, and the assembly from the bottom of the skid and are then secured with hex nuts. When the nuts are "snugged" down to the top of the base plate or casing and bearing housing feet, the rubber bushing is expanded, sealing the hole from the atmosphere. Desiccant bags are placed on the Tackwrap. The Tackwrap is drawn up around the assembly and hermetically (heat) sealed across the top. The assembly is completely sealed from the atmosphere and the desiccant will absorb any entrapped moisture. A solid wood box is then used to cover the assembly to provide protection from the elements and handling. This packaging will provide protection up to twelve months without damage to mechanical seals, bearings, lip seals, etc. due to humidity, salt laden air, dust, etc. After unpacking, protection will be the responsibility of the ENGINEERED PROCESS GROUP

user. Addition of oil to the bearing housing will remove the inhibitor. If units are to be idle for extended periods after addition of lubricants, inhibitor oils and greases should be used.

Every three months, the shaft should be rotated approximately 10 revolutions.

INSTALLATION & ALIGNMENT

FACTORY PRELIMINARY ALIGNMENT PROCEDURE

The purpose of factory alignment is to ensure that the user will have full utilization of the clearance in the motor holes for final job-site alignment. To achieve this, the factory alignment procedure specifies that the pump be aligned in the horizontal plane to the motor, with the motor foot bolts centered in the motor holes. This procedure ensures that there is sufficient clearance in the motor holes for the customer to field align the motor to the pump, to zero tolerance. This philosophy requires that the customer be able to place the base in the same condition as the factory. Thus the factory alignment will be done with the base sitting in an unrestrained condition on a flat and level surface. This standard also emphasizes the need to ensure the shaft spacing is adequate to accept the specified coupling spacer. The factory alignment procedure is summarized below:

1. The base plate is placed on a flat and level work bench in a free and unstressed position.
2. The base plate is leveled as necessary. Leveling is accomplished by placing shims under the rails (or, feet) of the base at the appropriate anchor bolt hole locations. Levelness is checked in both the longitudinal and lateral directions.
3. The motor and appropriate motor mounting hardware is placed on the base plate and the motor is checked for any planar soft-foot condition. If any is present it is eliminated by shimming.
4. The motor feet holes are centered around the motor mounting fasteners.
5. The motor is fastened in place by tightening the nuts on two diagonal motor mounting studs.
6. The pump is put onto the base plate and leveled. The foot piece under the bearing housing is adjustable. It is used to level the pump, if necessary. If an adjustment is necessary, we add or delete shims (#109A) between the foot piece and the bearing housing.
7. The spacer coupling gap is verified.

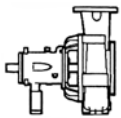

8. The parallel and angular *vertical* alignment is made by shimming under the motor.
9. All four motor feet are tightened down.
10. The pump and motor shafts are then aligned *horizontally*, both parallel and angular, by *moving the pump* to the fixed motor. The pump feet are tightened down.
11. Both horizontal and vertical alignment are again final checked as is the coupling spacer gap.

RECOMMENDED PROCEDURE FOR BASE PLATE INSTALLATION & FINAL FIELD ALIGNMENT

NEW GROUTED BASE PLATES

1. The pump foundation should be located as close to the source of the fluid to be pumped as practical. There should be adequate space for workers to install, operate, and maintain the pump. The foundation should be sufficient to absorb any vibration and should provide a rigid support for the pump and motor. Recommended mass of a concrete foundation should be three times that of the pump, motor and base. Note that foundation bolts are imbedded in the concrete inside a sleeve to allow some movement of the bolt.
2. Level the pump base plate assembly. If the base plate has machined coplanar mounting surfaces, these machined surfaces are to be referenced when leveling the base plate. This may require that the pump and motor be removed from the base plate in order to reference the machined faces. If the base plate is without machined coplanar mounting surfaces, the pump and motor are to be left on the base plate. The proper surfaces to reference when leveling the pump base plate assembly are the pump suction and discharge flanges. **DO NOT** stress the base plate. Do not bolt the suction or discharge flanges of the pump to the piping until the base plate foundation is completely installed. If equipped, use leveling jackscrews to level the base plate. If jackscrews are not provided, shims and wedges should be used (see figure 5). Check for levelness in both the longitudinal and lateral directions. Shims should be placed at all base anchor bolt locations, and in the middle edge of the base if the base is more than five feet long. Do not rely on the bottom of the base plate to be flat. Standard base plate bottoms are not machined, and it

is not likely that the field mounting surface is flat.

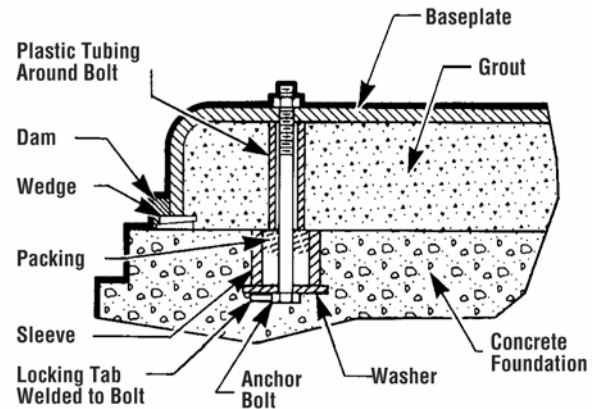
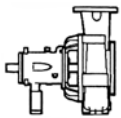

FIGURE 5 – Base Plate Foundation

3. After leveling the base plate, tighten the anchor bolts. If shims were used, make sure that the base plate was shimmed near each anchor bolt before tightening. Failure to do this may result in a twist of the base plate, which could make it impossible to obtain final alignment. Check the level of the base plate to make sure that tightening the anchor bolts did not disturb the level of the base plate. If the anchor bolts did change the level, adjust the jackscrews or shims as needed to level the base plate. Continue adjusting the jackscrews or shims and tightening the anchor bolts until the base plate is level.
4. Check initial alignment. If the pump and motor were removed from the base plate proceed with step 5 first, then the pump and motor should be reinstalled onto the base plate using American-Marsh's Factory Preliminary Alignment Procedure, and then continue with the following. As described above, pumps are given a preliminary alignment at the factory. This preliminary alignment is done in a way that ensures that, if the installer duplicates the factory conditions, there will be sufficient clearance between the motor hold down bolts and motor foot holes to move the motor into final alignment. If the pump and motor were properly reinstalled to the base plate or if they were not removed from the base plate and there has been no transit damage, and also if the above steps were done properly, the pump and driver should be within 0.015 in (0.38 mm) FIM (Full Indicator Movement)



parallel, and 0.0025 in/in (0.0025 mm/mm) FIM angular. If this is not the case first check to see if the driver mounting fasteners are centered in the driver feet holes. If not, recenter the fasteners and perform a preliminary alignment to the above tolerances by shimming under the motor for vertical alignment, and by moving the pump for horizontal alignment.

5. Grout the base plate. A non-shrinking grout should be used. Make sure that the grout fills the area under the base plate. After the grout has cured, check for voids and repair them. Jackscrews, shims and wedges should be removed from under the base plate at this time. If they were to be left in place, they could rust, swell, and cause distortion in the base plate.
6. Run piping to the suction and discharge of the pump. There should be no piping loads transmitted to the pump after connection is made. Recheck the alignment to verify that there are no significant loads.
7. Perform final alignment. Check for soft-foot under the driver. An indicator placed on the coupling, reading in the vertical direction, should not indicate more than 0.002 in (0.05 mm) movement when any driver fastener is loosened. Align the driver first in the vertical direction by shimming underneath its feet. When satisfactory alignment is obtained the number of shims in the pack should be minimized. It is recommended that no more than five shims be used under any foot. Final horizontal alignment is made by moving the driver. Maximum pump reliability is obtained by having near perfect alignment. American-Marsh recommends no more than 0.002 in (0.05mm) parallel, and 0.0005 in/in (0.0005 mm/mm) angular misalignment.
8. Operate the pump for at least an hour or until it reaches final operating temperature. Shut the pump down and recheck alignment while the pump is hot. Piping thermal expansion may change the alignment. Realign pump as necessary.

EXISTING GROUTED BASE PLATES

When a pump is being installed on an existing grouted base plate, the procedure is somewhat different from the previous section "New Grouted Base Plates."

1. Mount the pump on the existing base plate.
2. Level the pump by putting a level on the discharge flange. If not level, add or delete

shims (#109A) between the foot piece and the bearing housing.

3. Check initial alignment. (Step 4 above)
4. Run piping to the suction and discharge flanges of the pump. (Step 6 above)
5. Perform final alignment. (Step 7 above)
6. Recheck alignment after pump is hot. (Step 8 above)

All piping must be independently supported, accurately aligned and preferably connected to the pump by a short length of flexible piping. The pump should not have to support the weight of the pipe or compensate for misalignment. It should be possible to install suction and discharge bolts through mating flanges without pulling or prying either of the flanges. All piping must be tight. Pumps may air-bind if air is allowed to leak into the piping. If the pump flange(s) have tapped holes, select flange fasteners with thread engagement at least equal to the fastener diameter but that do not bottom out in the tapped holes before the joint is tight.

PIPING CONNECTION – SUCTION & DISCHARGE

All piping must be independently supported, accurately aligned and preferably connected to the pump by a short length of flexible piping. The pump should not have to support the weight of the pipe or compensate for misalignment. It should be possible to install suction and discharge bolts through mating flanges without pulling or prying either of the flanges. All piping must be tight. Pumps may air-bind if air is allowed to leak into the piping. If the pump flange(s) have tapped holes, select flange fasteners with thread engagement at least equal to the fastener diameter but that do not bottom out in the tapped holes before the joint is tight.



Piping Forces: Take care during installation and operation to minimize pipe forces and/or moments on the pump casing. Forces and moments must be kept within the limits given in Appendix F.

SUCTION PIPING

To avoid NPSH and suction problems, suction pipe sizes must be at least as large as the pump suction connection. **Never** use pipe or fittings on the suction that are smaller in diameter than the pump suction size. Figure 6 illustrates the ideal piping configuration with a minimum of 10 pipe diameters between the source and the pump suction. In most cases, horizontal reducers should be eccentric and mounted with the flat side up as shown in figure 6 with a maximum of one pipe size

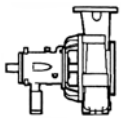

reduction. Never mount eccentric reducers with the flat side down. Horizontally mounted concentric reducers should not be used if there is any possibility of entrained air in the process fluid. Vertically mounted concentric reducers are acceptable. In applications where the fluid is completely deaerated and free of any vapor or suspended solids, concentric reducers are preferable to eccentric reducers.

Avoid the use of throttling valves and strainers in the suction line. Start up strainers must be removed shortly after start up. When the pump is installed below the source of supply, a valve should be installed in the suction line to isolate the pump and to permit pump inspection and maintenance. However, never place a valve directly on the suction nozzle of the pump.

Refer to the American-Marsh Pump Engineering Manual and the Centrifugal Pump IOM Section of the Hydraulic Institute Standards for additional recommendations on suction piping. (See Appendix A)

Suction pressure limits for OSD pumps with reverse vane impellers are given in Figure 4. The curves show maximum allowable suction pressure at various specific gravities. Note that Class 300 flanges may be necessary. Note also that for front vane semi-open impellers the suction pressure is limited only by the pressure/ temperature curves shown in Figure 2.

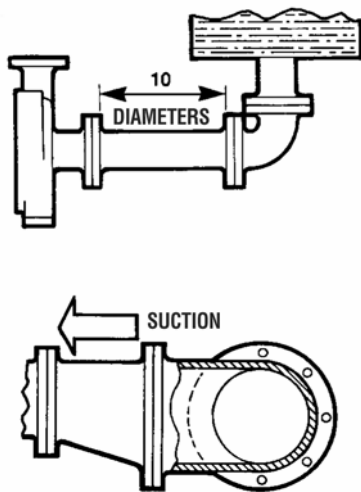

FIGURE 6 – Good Piping Practices

! WARNING

The pressure temperature ratings shown in Figure 2 must not be exceeded. Suction pressure is limited only by the pressure temperature ratings, for pump sizes 8x10-14, 6x8-16A, 8x10-16 and 8x10-16H up through 2.0 specific gravity. Consult factory for specific gravity greater than 2.0.

DISCHARGE PIPING

Install a valve in the discharge line. This valve is required for regulating flow and/or to isolate the pump for inspection and maintenance.

! WARNING

When fluid velocity in the pipe is high, for example, 10 ft/s (3 m/s) or higher, a rapidly closing discharge valve can cause a damaging pressure surge. A dampening arrangement should be provided in the piping.

PUMP AND SHAFT ALIGNMENT CHECK

After connecting piping, rotate the pump drive shaft clockwise (view from motor end) by hand several complete revolutions to be sure there is no binding and that all parts are free. Recheck shaft alignment. If piping caused unit to be out of alignment, correct piping to relieve strain on the pump.

MECHANICAL SEAL

When the pump is intended to be equipped with a mechanical seal, it is American-Marsh's standard practice to install the mechanical seal in the pump prior to shipment. Specific order requirements may specify that the seal be shipped separately, or none be supplied. It is the pump installer's responsibility to determine if a seal was installed. If a seal was supplied but not installed, the seal and installation instructions will be shipped with the pump.

! WARNING

Failure to ensure that a seal is installed may result in serious leakage of the pumped fluid.

Seal and seal support system must be installed and operational as specified by the seal manufacturer.

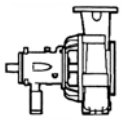

The stuffing box/seal chamber/gland may have ports that have been temporarily plugged at the factory to keep out foreign matter. It is the installer's responsibility to determine if these plugs should be removed and external piping connected. Refer to the seal drawings and/or the local American-Marsh representative for the proper connections.

PACKING

When the pump is intended to be equipped with shaft packing, it is not American-Marsh's standard practice to install the packing in the stuffing box prior to shipment. The packing is shipped with the pump. It is the pump installer's responsibility to install the packing in the stuffing box.



Failure to ensure that packing is installed may result in serious leakage of the pumped fluid.

PIPING CONNECTION –SEAL/PACKING SUPPORT SYSTEM



If the pump has a seal support system, it is mandatory that this system be fully installed and operational before the pump is started.

If packing is used:

Packing Lubrication – Water, when compatible with the pumpage, should be introduced into Tap V (Figure 7) at pressure 10 to 15 lbf/in² (69 to 103 kPa) above the stuffing box pressure.

The gland should be adjusted to give a flow rate of 20 to 30 drops per minute for clean fluid. For abrasive applications, the regulated flow rate should be 1-2 gpm (0.06-0.13 l/s).

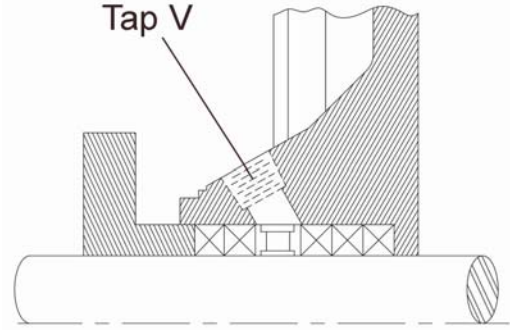

FIGURE 7

Grease lubrication, when compatible with the pumpage, may be used. Again, introduced into Tap V. In non-abrasive applications the pumpage itself may be sufficient to lubricate the packing without need for external lines. Tap V should be plugged.

Abrasive Packing Arrangement – The installation procedures are the same as the standard packing with some exceptions. A special lip seal is installed first, followed by two lantern ring assemblies, then two of the packing rings provided (Figure 8).

A flush line from a clean external source should be connected via Tap V, in the top of the stuffing box.

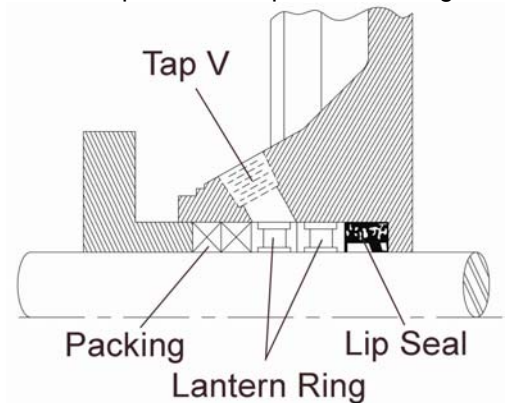

FIGURE 8

PIPING CONNECTION –BEARING HOUSING COOLING SYSTEM

Make connections as shown below. Liquid at less than 90°F (32°C) should be supplied at a regulated flow rate of at least 1 gpm (0.06 l/s).

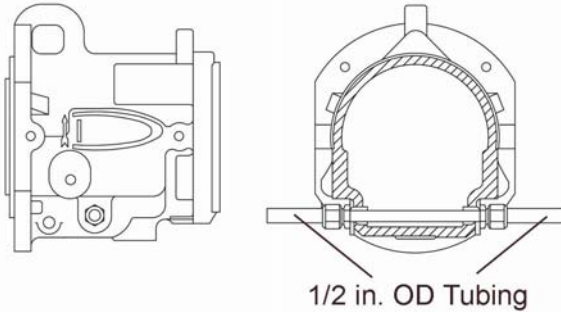
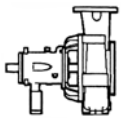

FIGURE 9 – Bearing Housing Cooling

PIPING CONNECTION – SUPPORT LEG COOLING FOR CENTERLINE MOUNTING OPTION

If the casing is centerline mounted, and the process temperature is over 350°F (178°C), then the casing support legs may need to be cooled (figure 10). Cool water (less than 90°F (32°C)) should be run through the legs at a flow rate of at least 1 gpm (0.06 l/s) as shown below.

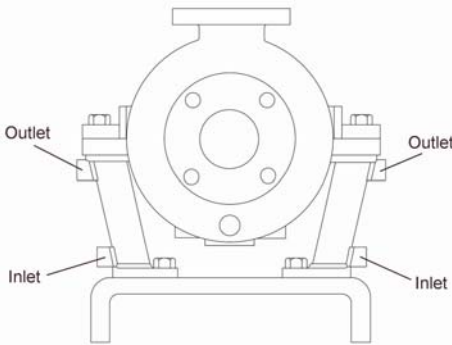

FIGURE 10 – Support Leg Cooling

PIPING CONNECTION – HEATING/COOLING FLUID FOR JACKETED COVER/CASING

The piping connections for jacketed covers and casings are shown below (figure 11). The flow rate of the cooling water (less than 90°F (32°C)) should be at least 2 gpm (0.13 l/s).

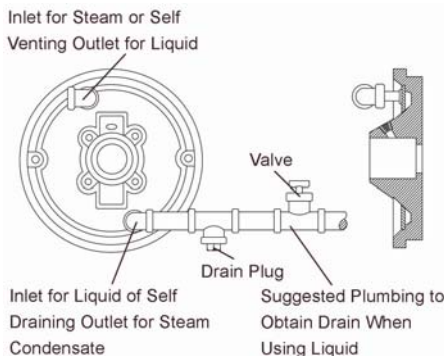

FIGURE 11 – Seal Chamber Cooling

PIPING CONNECTION – OIL MIST LUBRICATION SYSTEM

The piping connections for an oil mist lubrication system are shown in Figures 12 & 13.

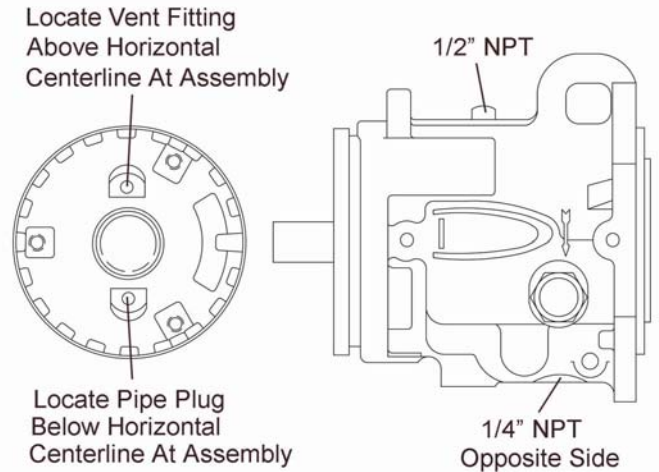

FIGURE 12 – Oil Mist Lubrication – Wet Sump

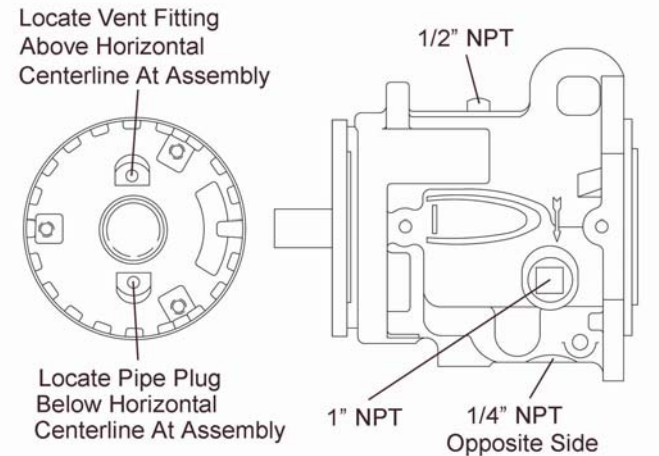
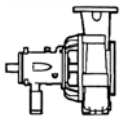

FIGURE 13 – Oil Mist Lubrication – Dry Sump



COUPLING

A direction arrow is cast on the front of the casing and on the Bearing Housing. Make sure the motor rotates in the same direction before coupling the motor to the Pump.

CAUTION

It is absolutely essential that the rotation of the motor be checked before connecting the shaft coupling. Incorrect rotation of the pump, for even a short time, can dislodge the impeller which may cause serious damage to the pump. All OSD pumps turn clockwise as viewed from the motor end or, conversely, counterclockwise when viewed from the suction end.

The coupling should be installed as advised by the coupling manufacturer. Pumps are shipped without the spacer installed. If the spacer has been installed to facilitate alignment, then it must be removed prior to checking rotation. Remove protective material from the coupling and any exposed portions of the shaft before installing the coupling.

PUMP OPERATION

ROTATION CHECK

CAUTION

It is absolutely essential that the rotation of the motor be checked before connecting the shaft coupling. Incorrect rotation of the pump, for even a short time, can dislodge and damage the impeller, casing, shaft and shaft seal.

All OSD pumps turn clockwise as viewed from the motor end. A direction arrow is cast on the front of the casing. Make sure the motor rotates in the same direction.

PRE START-UP CHECKS

Prior to starting the pump it is essential that the following checks are made. These checks are all described in detail in the Maintenance Section of this booklet.

- Pump and Motor properly secured to the base plate
- All fasteners tightened to the correct torques
- Coupling guard in place and not rubbing
- Rotation check, see above

THIS IS ABSOLUTELY ESSENTIAL.

- Impeller clearance setting
- Shaft seal properly installed
- Seal support system operational
- Bearing lubrication
- Bearing housing cooling system operational
- Support leg cooling for centerline mounting option operational
- Heating/cooling for jacketed casing/cover operational
- Pump instrumentation is operational
- Pump is primed
- Rotation of shaft by hand

As a final step in preparation for operation, it is important to rotate the shaft by hand to be certain that all rotating parts move freely, and that there are no foreign objects in the pump.

ENSURING PROPER NPSH_A

Net Positive Suction Head – Available (NPSH_A) is the measure of the energy in a liquid above the vapor pressure. It is used to determine the likelihood that a fluid will vaporize in the pump. It is critical because a centrifugal pump is designed to pump a liquid, not a vapor. Vaporization in a pump will result in damage to the pump, deterioration of the Total Differential Head (TDH), and possibly a complete stopping of pumping. Net Positive Suction Head – Required (NPSH_R) is the decrease of fluid energy between the inlet of the pump, and the point of lowest pressure in the pump. This decrease occurs because of friction losses and fluid accelerations in the inlet region of the pump, and particularly accelerations as the fluid enters the impeller vanes. The value for NPSH_R for the specific pump purchased is given in the pump data sheet, and on the pump performance curve.

For a pump to operate properly the NPSH_A must be greater than the NPSH_R. Good practice dictates that this margin should be at least 5 ft (1.5 m) or 20%, whichever is greater.

CAUTION

Ensuring that NPSH_A is larger than NPSH_R by the suggested margin will greatly enhance pump performance and reliability. It will also reduce the likelihood of cavitation, which can severely damage the pump.

MINIMUM FLOW

Minimum continuous stable flow is the lowest flow at which the pump can operate and still conform to the bearing life, shaft deflection and bearing housing

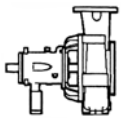

vibration limits of ANSI/ASME B73.1M-1991. Pumps may be operated at lower flows, but it must be recognized that the pump may not conform to one or more of these limits. For example, vibration may exceed the limit set by the ASME standard. The size of the pump, the energy absorbed, and the liquid pumped are some of the considerations in determining the minimum flow.

Typically, limitations of 10% of the capacity at the best efficiency point (BEP) should be specified as the minimum flow. However, American-Marsh has determined that several pumps must be limited to higher minimum flows to provide optimum service. The following are the recommended minimum flows for these specific pumps:

Pump Size	60 Hz		50 Hz	
	RPM	Minimum Flow (% of BEP)	RPM	Minimum Flow (% of BEP)
1L2x3-6	3500	25%	2900	21%
2L2x3-8	3500	25%	2900	21%
2L3x4-8	3500	25%	2900	21%
2L2x3-10	3500	33%	2900	28%
2L3x4-10	3500	33%	2900	28%
2L4x6-10	3500	50%	2900	42%
2L2x3-13	3500	50%	2900	42%
2L3x4-13	3500	50%	2900	42%
2L4x6-13	1750	50%	1450	42%
All GRP III*	1750	50%	1450	42%
All Other Sizes	ANY	10%	ANY	10%

*In some cases, the 3L4x6-16 can be used at lower than 50% of BEP, by making a modification. Contact American-Marsh Engineering if this pump is to be used at a lower flow.

FIGURE 14 – Minimum Continuous Safe Flow

Note: “Minimum intermittent flow” value of 50% of the “minimum continuous flow” as long as that flow is greater than the “minimum thermal flow.”

Note: The Lo-Flo pump is not covered by this table. See OSD Lo-Flo on page 7.

All OSD pumps also have a “Minimum Thermal Flow.” This is defined as the minimum flow that will not cause an excessive temperature rise. Minimum Thermal Flow is application dependent.



Do not operate the pump below Minimum Thermal Flow, as this could cause an excessive temperature rise. Contact an American-Marsh Sales Engineer for determination of Minimum Thermal flow.

STARTING THE PUMP AND ADJUSTING FLOW

1. Open the suction valve to full open position. It is very important to leave the suction valve open while the pump is operating. Any throttling or adjusting of flow must be done through the discharge valve. Partially closing the suction valve can create serious NPSH and pump performance problems.



Never operate pump with both the suction and discharge valves closed. This could cause an explosion.

2. A standard centrifugal pump will not move liquid unless the pump is primed. A pump is said to be “primed” when the casing and the suction piping are completely filled with liquid. Open discharge valve a slight amount. This will allow any entrapped air to escape and will normally allow the pump to prime, if the suction source is above the pump. When a condition exists where the suction pressure may drop below the pump’s capability, it is advisable to add a low pressure control device to shut the pump down when the pressure drops below a predetermined minimum.
3. All cooling, heating, and flush lines must be started and regulated.
4. Start the driver (typically, the electric motor).
5. Slowly open the discharge valve until the desired flow is reached, keeping in mind the minimum flow restrictions listed above.



It is important that the discharge valve be opened within a short interval after starting the driver. Failure to do this could cause a dangerous build up of heat, and possibly an explosion.

6. **Reduced capacity**
Avoid running a centrifugal pump at drastically reduced capacities or with discharge valve closed for extended periods of time. This can cause severe temperature rise and the liquid in the pump may reach its boiling point. If this occurs, the mechanical seal will be exposed to vapor, with no lubrication, and may score or

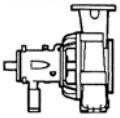

seize to the stationary parts. Continued running under these conditions when the suction valve is also closed, can create an explosive condition due to the confined vapor at high pressure and temperature. Thermostats may be used to safeguard against over heating by shutting down the pump at a predetermined temperature.

Safeguards should also be taken against possible operation with a closed discharge valve, such as installing a bypass back to the suction source. The size of the bypass line and the required bypass flow rate is a function of the input horsepower and the allowable temperature rise.

7. *Reduced Head*

Note that when discharge head drops, the pump's flow rate usually increases rapidly. Check motor for temperature rise as this may cause overload. If overloading occurs, throttle the discharge.

8. *Surging Condition*

A rapidly closing discharge valve can cause a damaging pressure surge. A dampening arrangement should be provided in the piping.

impossible to cover every possible scenario. If a problem exists that is not covered by one of the examples, then contact a local American-Marsh Sales Engineer or Distributor/Representative for assistance.

OPERATION IN SUB-FREEZING CONDITIONS

When using the pump in sub-freezing conditions where the pump is periodically idle, the pump should be properly drained or protected with thermal devices which will keep the liquid in the pump from freezing. High chrome iron pumps are not recommended for applications below 0°F (-18°C).

SHUTDOWN CONSIDERATIONS

When the pump is being shutdown, the procedure should be the reverse of the start-up procedure. First, slowly close the discharge valve, shutdown the driver, then close the suction valve. Remember, closing the suction valve while the pump is running is a safety hazard and could seriously damage the pump and other equipment.

TROUBLESHOOTING

The following is a guide to troubleshooting problems with American-Marsh pumps. Common problems are analyzed and solutions are offered. Obviously, it is

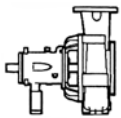

PROBLEM	POSSIBLE CAUSE	RECOMMENDED REMEDY
Problem #1 Pump not reaching design flow rate.	1.1 Insufficient NPSH _A . (Noise may not be present)	Recalculate NPSH available. It must be greater than the NPSH required by pump at desired flow. If not, redesign suction piping, holding number of elbows and number of planes to a minimum to avoid adverse flow rotation as it approaches the impeller.
	1.2 System head greater than anticipated.	Reduce system head by increasing pipe size and/ than or reducing number of fittings. Increase impeller diameter. NOTE: Increasing impeller diameter may require use of a larger motor.
	1.3 Entrained air. Air leak from atmosphere on suction side.	1. Check suction line gaskets and threads for tightness. 2. If vortex formation is observed in suction tank, install vortex breaker. 3. Check for minimum submergence.
	1.4 Entrained gas from process.	Process generated gases may require larger pumps.
	1.5 Speed too low.	Check motor speed against design speed.
	1.6 Direction of rotation wrong.	After confirming wrong rotation, reverse any two of three leads on a three phase motor. The pump should be disassembled and inspected before it is restarted.
	1.7 Impeller too small.	Replace with proper diameter impeller. NOTE: Increasing impeller diameter may require use of a larger motor.
	1.8 Impeller clearance too large.	Reset impeller clearance.
	1.9 Plugged impeller, suction line or casing which may be due to a product or large solids.	1. Reduce length of fiber when possible. 2. Reduce solids in the process fluid when possible. 3. Consider larger pump.
	1.10 Wet end parts (casing cover, impeller) worn, corroded or missing.	Replace part or parts.
Problem #2.0 Pump not reaching design head (TDH).	2.1 Refer to possible causes under Problem #1.0.	Refer to remedies listed under Problem #1.0 and #3.0.
Problem #3.0 No discharge or flow	3.1 Not properly primed.	Repeat priming operation, recheck instructions. If pump has run dry, disassemble and inspect the pump before operation.
	3.2 Direction of rotation wrong.	After confirming wrong rotation, reverse any two of three leads on a three phase motor. The pump should be disassembled and inspected before operation.

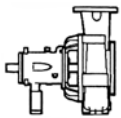

PROBLEM	POSSIBLE CAUSE	RECOMMENDED REMEDY
Cont. Problem #3.0 No discharge or flow	3.3 Entrained air. Air leak from atmosphere on suction side.	Refer to recommended remedy under Problem #1.0, Item #1.3.
	3.4 Plugged impeller, suction line or casing which may be due to a fibrous product or large solids.	Refer to recommended remedy under Problem #1.0, Item #1.9.
	3.5 Damaged pump shaft, impeller.	Replace damaged parts.
Problem #4.0 Pump operates for short period, then loses prime.	4.1 Insufficient NPSH.	Refer to recommended remedy under Problem #1.0, Item #1.1.
	4.2 Entrained air. Air leak from atmosphere on suction side.	Refer to recommended remedy under Problem #1.0, Item #1.3.
Problem #5.0 Excessive noise from wet end.	5.1 Cavitation - insufficient NPSH available.	Refer to recommended remedy under Problem #1.0, Item #1.1.
	5.2 Abnormal fluid rotation due to complex suction piping.	Redesign suction piping, holder number of elbows and number of planes to a minimum to avoid adverse fluid rotation as it approaches the impeller.
	5.3 Impeller rubbing.	1. Check and reset impeller clearance. 2. Check outboard bearing assembly for axial end play.
Problem #6.0 Excessive noise from power end.	6.1 Bearing contamination appearing on the raceways as scoring, pitting, scratching, or rusting caused by adverse environment and entrance of abrasive contaminants from atmosphere.	1. Work with clean tools in clean surroundings. 2. Remove all outside dirt from housing before exposing bearings. 3. Handle with clean dry hands. 4. Treat a used bearing as carefully as a new one. 5. Use clean solvent and flushing oil. 6. Protect disassembled bearing from dirt and moisture. 7. Keep bearings wrapped in paper or clean cloth while not in use. 8. Clean inside of housing before replacing bearings. 9. Check oil seals and replace as required. 10. Check all plugs and tapped openings to make sure that they are tight.
	6.2 Brinelling of bearing identified by indentation on the ball races, usually caused by incorrectly applied forces in assembling the bearing or by shock loading such as hitting the bearing or drive shaft with a hammer.	When mounting the bearing on the drive shaft use a proper size ring and apply the pressure against the inner ring only. Be sure when mounting a bearing to apply the mounting pressure slowly and evenly.

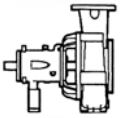

PROBLEM	POSSIBLE CAUSE	RECOMMENDED REMEDY
Cont. Problem #6.0 Excessive noise from power end.	6.3 False brinelling of bearing identified again by either axial or circumferential indentations usually caused by vibration of the balls between the races in a stationary bearing.	1. Correct the source of vibration. 2. Where bearings are oil lubricated and employed in units that may be out of service for extended periods, the drive shaft should be turned over periodically to re-lubricate all bearing surfaces at intervals of one-to three months.
	6.4 Thrust overload on bearing identified by flaking ball path on one side of the outer race or in the case of maximum capacity bearings, may appear as a spalling of the races in the vicinity of the loading slot. (Please note: maximum capacity bearings are not recommended in OSD pumps.) These thrust failures are caused by improper mounting of the bearing or excessive thrust loads.	1. Follow correct mounting procedures for bearings.
	6.5 Misalignment identified by fracture of ball retainer or a wide ball path on the inner race and a narrower cocked ball path on the outer race. Misalignment is caused by poor mounting practices or defective drive shaft. For example bearing not square with the centerline or possibly a bent shaft due to improper handling.	Handle parts carefully and follow recommended mounting procedures. Check all parts for proper fit and alignment.
	6.6 Bearing damaged by electric arcing identified as electro-etching of both inner and outer ring as a pitting or cratering. Electrical arcing is caused by a static electrical charge emanating from belt drives, electrical leakage or short circuiting.	1. Where current shunting through the bearing cannot be corrected, a shunt in the form of a slip ring assembly should be incorporated. 2. Check all wiring, insulation and rotor windings to be sure that they are sound and all connections are properly made. 3. Where pumps are belt driven, consider the elimination of static charges by proper grounding or consider belt material that is less generative.

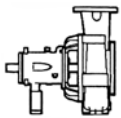

PROBLEM	POSSIBLE CAUSE	RECOMMENDED REMEDY
Cont.: Problem #6.0 Excessive noise from power end.	6.7 Bearing damage due to improper lubrication, identified by one or more of the following: 1. Abnormal bearing temperature rise. 2. A stiff cracked grease appearance. 3. A brown or bluish discoloration of the bearing races.	1. Be sure the lubricant is clean. 2. Be sure proper amount of lubricant is used. The constant level oiler supplied with OSD pumps will maintain the proper oil level if it is installed and operating properly. In the case of greased lubricated bearings, be sure that there is space adjacent to the bearing into which it can rid itself of excessive lubricant, otherwise the bearing may overheat and fail prematurely. 3. Be sure the proper grade of lubricant is used.

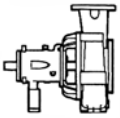

MAINTENANCE

PREVENTIVE MAINTENANCE

The following sections of this manual give instructions on how to perform a complete maintenance overhaul. However, it is also important to periodically repeat the "Pre start-up checks" listed on page 17. These checks will help extend pump life as well as the length of time between major overhauls.

NEED FOR MAINTENANCE RECORDS

A procedure for keeping accurate maintenance records is a critical part of any program to improve pump reliability. There are many variables that can contribute to pump failures. Often long term and repetitive problems can only be solved by analyzing these variables through pump maintenance records.

NEED FOR CLEANLINESS

One of the major causes of pump failure is the presence of contaminants in the bearing housing. This contamination can be in the form of moisture, dust, dirt and other solid particles such as metal chips. Contamination can also be harmful to the mechanical seal (especially the seal faces) as well as other parts of the pumps. For example, dirt in the impeller threads could cause the impeller to not be seated properly against the shaft. This, in turn, could cause a series of other problems. For these reasons, it is very important that proper cleanliness be maintained. Some guidelines are listed below.

After draining the oil from the bearing housing, periodically send it out for analysis. If it is contaminated, determine the cause and correct. The work area should be clean and free from dust, dirt, oil, grease, etc. Hands and gloves should be clean. Only clean towels, rags, and tools should be used.

DISASSEMBLY

Refer to the parts list shown in Figure 31, 32, 33 & 34 for item number references used throughout this section.

1. Before performing any maintenance, disconnect the driver from its power supply and lock it off line.

DANGER

Lock out power to driver to prevent personal injury.

2. Close the discharge and suction valves, and drain all liquid from the pump.
3. Close all valves on auxiliary equipment and piping, then disconnect all auxiliary piping.
4. Decontaminate the pump as necessary. *If American-Marsh pumps contain dangerous chemicals, it is important to follow plant safety guidelines to avoid personal injury or death.*
5. Remove the coupling guard. (See page 17 on Coupling Guards.)
6. Remove the spacer from the coupling.
7. Remove casing fasteners (#115A).
8. Remove the fasteners holding the bearing housing foot to the base plate.
9. Move the power end, rear cover, and seal chamber assembly away from the casing. Discard the casing/cover gasket (#107).

DANGER

The power end and rear cover assembly is heavy. It is important to follow plant safety guidelines when lifting it.

10. Transport the assembly to the maintenance shop.
11. Remove the coupling hub from the pump shaft (#105).
12. Using the shaft key (#130) and with the wrench handle pointing to the left when viewed from the impeller end, grasp the impeller (#103) firmly with both hands (wear heavy gloves), by turning the impeller in the clockwise direction move the wrench handle to the 11:00 o'clock position and then spin the impeller quickly in a counterclockwise direction so that the wrench makes a sudden impact with a hard surface on the bench. After several sharp raps, the impeller should be free. Unscrew the impeller and remove from the shaft. Discard the impeller gasket (#104).

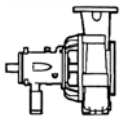

! CAUTION

Do not apply heat to the impeller. If liquid is entrapped in the hub, an explosion could occur.

Refer to Appendix D for instructions on removing the seal, sleeve, and rear cover plate if pump is equipped with an FMI seal chamber. This is the American-Marsh seal chamber that does not have a separate gland. The gland is integral to the seal chamber.

13. Remove the seal or packing gland nuts (#111A).
14. Remove the two cap screws (#140) which attach the rear cover plate to the adapter. Carefully remove the rear cover plate (#106).
15. If a cartridge type mechanical seal (#153) is used, loosen the set screws which lock the unit to the shaft and remove the complete seal assembly. If the seal is to be reused, the spacing clips or tabs should be reinstalled prior to loosening the set screws. This will ensure that the proper seal compression is maintained.
16. If a component type inside mechanical seal (#153) is used, loosen the set screws on the rotating unit and remove it from the shaft, see Figure 23. Then pull the gland (#190) and stationary seat off the shaft. Remove the stationary seat from the gland. Discard all O-rings and gaskets.
17. If a component type outside mechanical seal is used, remove the gland and the stationary seat. Remove the stationary seat from the gland. Loosen the set screws in the rotating unit and remove it. Discard all O-rings and gaskets.
18. If packing (#113) is used, remove it and the seal cage (lantern ring)(#112). Remove the gland (#110).
19. If the pump has a hook type sleeve (#177) it can now be removed.
20. If the power end is oil lubricated, remove the drain plug (#134) and drain the oil from the bearing housing (#119).
21. If the pump has lip seals, a deflector (#114) will be present. Remove it.
22. Loosen the three set screws (#201A) on the bearing carrier (#201). The bearing carrier must be completely unscrewed from the bearing housing. **Note: Do not pry against the shaft.** The face of the bearing carrier has three square lugs that protrude from the surface. The bearing carrier is turned by using an open end wrench on one of the square lugs.

23. Because the O-rings (#201B) will cause some resistance in removing the bearing carrier assembly from the housing, hold the bearing carrier flange firmly and with slight rotation, pull it out of the bearing housing. The bearing carrier assembly with the shaft and bearings should come free. Further disassembly is not required unless the bearings are to be replaced.
24. Remove the snap ring (#201C) (Figure 26) on Group 1 and 2 pumps, or the bearing retainer (#201D) on Group 3 pumps.
Note: Group 1 and 2 pumps equipped with duplex angular contact bearings use a bearing retainer (#201D) instead of the snap ring. Remove the carrier from the bearing.
25. The bearing locknut (#124) and lock washer (#125) may now be removed from the shaft (#105). Discard the lock washer.
26. An arbor or hydraulic press may be used to remove the bearings (#120 and #121) from the shaft. It is extremely important to apply even pressure to the inner bearing race only. Never apply pressure to the outer race as this exerts excess load on the balls and causes damage.

! CAUTION

Applying pressure to the outer race could permanently damage the bearings.

27. The OSD design has an optional oil slinger (#122) located between the bearings. If present, inspect it for damage or looseness. Remove if it needs to be replaced.
28. On Group 2 and 3 pumps, the bearing housing (#119) must be separated from the bearing housing adapter (#108). This is accomplished by removing the cap screws (#139) which thread into the bearing housing.
29. If lip seals (#118) and (#129) (Figure 27) are used, they should be removed from the bearing housing and adapter and discarded. If bearing isolators are used, refer to Appendix E.
30. If magnetic seals are used, maintain the seals as specified by the manufacturer.
31. If present, the Trico oiler (#133) (Figure 28) should be removed from the bearing housing.
32. The sight gage (#200) (Figure 29) should be removed from the bearing housing.

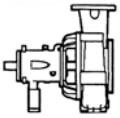

CLEANING/INSPECTION

All parts should now be thoroughly cleaned and inspected. New bearings, O-rings, gaskets, and lip seals should be used. Any parts that show wear or corrosion should be replaced with new genuine American-Marsh parts.

! WARNING

It is important that only non-flammable, non-contaminated cleaning fluids are used. These fluids must comply with plant safety and environmental guidelines.

CRITICAL MEASUREMENT AND TOLERANCES

To maximize reliability of pumps, it is important that certain parameters and dimensions are measured and maintained within specified tolerances. Please refer to Appendix A for a summary of these various physical parameters and the associated tolerances which are vital for maximizing pump reliability. It is very important that all parts be checked as specified in Appendix A. Any parts that do not conform to the specifications should be replaced with new American-Marsh parts.

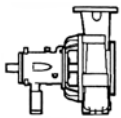

ASSEMBLY

Note: Refer to Figure 15 for all bolt torque information.

It is very important that all pipe threads be sealed properly. PTFE tape provides a very reliable seal over a wide range of fluids, but it has a serious shortcoming if not used properly. If, during application to the threads, the tape is wrapped over the end of the male thread, strings of the tape will be formed off when threaded into the female fitting. This string can then tear away and lodge in the piping system. If this occurs in the seal flush system, small orifices can become blocked effectively shutting off flow. For this reason, American-

Marsh does not recommend the use of PTFE tape as a thread sealant.

American-Marsh has investigated and tested alternate sealants and has identified two that provide an effective seal, have the same chemical resistance as the tape, and will not plug flush systems. These are La-co SlicTite and Bakerseal. Both products contain finely ground PTFE particles in an oil based carrier. They are supplied in a paste form which is brushed on the male pipe threads. American-Marsh recommends using one of these paste sealants.

Full thread length engagement is required for all fasteners.

Item	Description	Group 1 Non-lubricated	Group 2 Non-lubricated	Group 3 Non-lubricated
201E	Bearing retainer cap screws - standard bearings	N/A	N/A	5/16 in - 12 ft•lbf
201E	Bearing retainer cap screws - duplex bearings	3/16 in - 4 ft•lbf	3/16 in - 4 ft•lbf	5/16 in - 12 ft•lbf
139	Bearing housing/adaptor cap screws and nuts	N/A	1/2 in - 40 ft•lbf	5/8 in - 90 ft•lbf
111	Mechanical seal gland studs/nuts, with gasket	3/8 in - 12 ft•lbf	3/8 in - 12 ft•lbf	1/2 in - 30 ft•lbf
111	Mechanical seal gland studs/nuts, with O-ring\	3/8 in - 20 ft•lbf	3/8 in - 20 ft•lbf	1/2 in - 40 ft•lbf
115	Casing studs/nuts	1/2 in - 30 ft•lbf	1/2 in - 30 ft•lbf 5/8 in - 60 ft•lbf	3/4 in - 100 ft•lbf 7/8 in - 160 ft•lbf
140	Cap screw cover/adaptor (token bolts)	3/8 in - 20 ft•lbf	3/8 in - 20 ft•lbf	1/2 in - 40 ft•lbf
201A	Bearing carrier set screws	3/8 in - 12 ft•lbf	1/2 in - 30 ft•lbf	1/2 in - 30 ft•lbf
136	Cap screw foot	1/2 in - 40 ft•lbf	3/4 in - 160 ft•lbf	1 in - 228 ft•lbf

Note: 1.) For lubricated threads, use 75% of the values given. 2.) Gasket joint torque values are for un-filled PTFE gaskets. Harder gasket materials may require more torque to seal. Exceeding metal joint torque values is not recommended.

Item	Description	Group 1 Non-lubricated	Group 2 Non-lubricated	Group 3 Non-lubricated
201E	Bearing retainer cap screws - standard bearings	N/A	N/A	5/16 in - 16 N•m
201E	Bearing retainer cap screws - duplex bearings	3/16 in - 6 N•m	3/16 in - 6 N•m	5/16 in - 16 N•m
139	Bearing housing/adaptor cap screws and nuts	N/A	1/2 in - 54 N•m	5/8 in - 122 N•m
111	Mechanical seal gland studs/nuts, with gasket	3/8 in - 16 N•m	3/8 in - 16 N•m	1/2 in - 41 N•m
111	Mechanical seal gland studs/nuts, with O-ring\	3/8 in - 27 N•m	3/8 in - 27 N•m	1/2 in - 54 N•m
115	Casing studs/nuts	1/2 in - 41 N•m	1/2 in - 41 N•m 5/8 in - 81 N•m	3/4 in - 136 N•m 7/8 in - 217 N•m
140	Cap screw cover/adaptor (token bolts)	3/8 in - 27 N•m	3/8 in - 27 N•m	1/2 in - 54 N•m
201A	Bearing carrier set screws	3/8 in - 16 N•m	1/2 in - 41 N•m	1/2 in - 41 N•m
136	Cap screw foot	1/2 in - 54 N•m	3/4 in - 217 N•m	1 in - 300 N•m

Note: For lubricated or PTFE-coated threads, use 75% of the values given.

FIGURE 15 – Recommended Bolt Torques (US & Metric Units)

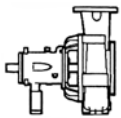

POWER END ASSEMBLY

The OSD design has an optional oil slinger. If the slinger was removed during disassembly, install a new slinger (#122).

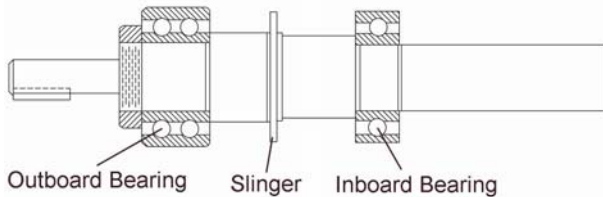

FIGURE 16 – Typical Shaft Arrangement

BEARING INSTALLATION

Mounting of bearings on shafts must be done in a clean environment. Bearing and power end life can be drastically reduced if even very small foreign particles work their way into the bearings.

Bearings should be removed from their protective packaging only immediately before assembly to limit exposure to possible contamination. After removing the

packaging they should only come in contact with clean hands, fixtures, tools and work surfaces.

The chart shown in Figure 18 gives the SKF part numbers for bearings in American-Marsh OSD pumps. Note that the term “inboard bearing” refers to the bearing nearest to the casing. “Outboard bearing” refers to the bearing nearest to the motor.

1. Install the inboard bearing (#120) on the shaft (#105). The inboard bearing must be positioned against the shoulder as shown in Figure 36. If the power end is equipped with single shield re-greaseable bearings, the shields should be oriented as shown in Figure 17.

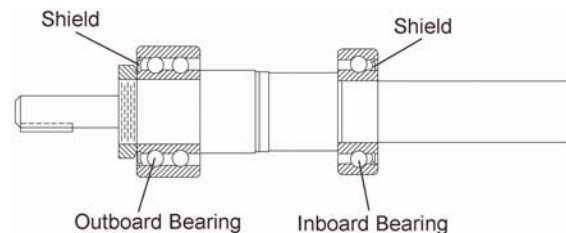

FIGURE 17 – Shielded Bearing Arrangement

Group	Type of Bearings	Inboard Single Row, Deep Groove ^⑤	Outboard Double Row, Angular Contact, Deep Groove ^⑤	Optional Outboard Duplex Angular Contact ^⑤
1	Oil bath/mist – Open ^① Regreasable – Single Shielded ^② Greased for life – Double Shielded ^③ Sealed for life – Double Sealed ^④	6207-C3 6207-ZC3 6207-2ZC3 6207-2RSIC3	5306-AC3 5306-AZC3 5306-A2ZC3 5306-A2RSC3	7306-BECBY NA ^⑥ NA ^⑦ NA ^⑦
2	Oil bath/mist – Open ^① Regreasable – Single Shielded ^② Greased for life – Double Shielded ^③ Sealed for life – Double Sealed ^④	6310-C3 6310-ZC3 6310-2ZC3 6310-2RSIC3	5310-AHC3 5310-AZC3 5310-A2ZC3 5310-A2RSC3	7310-BECBY NA ^⑥ NA ^⑦ NA ^⑦
3	Oil bath/mist – Open ^① Regreasable – Single Shielded ^② Greased for life – Double Shielded ^③ Sealed for life – Double Sealed ^④	6314-C3 6314-ZC3 6314-2ZC3 6314-2RSIC3	5314-AC3 5314-AZC3 5314-A2ZC3 5314-A2RSC3	7314-BECBY NA ^⑥ NA ^⑦ NA ^⑦

FIGURE 18 – AMP OSD Bearings

^①These bearings are open on both sides. They are lubricated by oil bath or oil mist.

^②These bearings are pre-greased by American-Marsh. Replacement bearings will generally not be pre-greased, so grease must be applied by the user. They have a single shield, which is located on the side next to the grease buffer, or reservoir. The bearings draw grease from the reservoir as it is needed. The shield protects the bearing from getting too much grease, which would generate heat. The grease reservoir is initially filled with grease by American-Marsh. Lubrication fittings are provided, to allow the customer to periodically replenish the grease, as recommended by the bearing and/or grease manufacturer.

^③These bearings are shielded on both sides. They come pre-greased by the bearing manufacturer. The user does not need to re-grease these bearings. The shields do not actually contact the bearing race, so no heat is generated.

^④These bearings are sealed on both sides. They come pre-greased by the bearing manufacturer. The user does not need to re-grease these bearings. The seals physically contact and rub against the bearing race, which generates heat. These bearings are not recommended at speeds above 1750 RPM.

^⑤The codes shown are SKF codes. Inboard and outboard bearings have the C3, greater than “Normal” clearance. These clearances are recommended by SKF to maximize bearing life.

^⑥Re-greasable – Single Shielded bearings are not available in the duplex configuration; however, open oil bath-type bearings can be used for the re-greasable configuration. These bearings must be pre-greased during assembly. Lubrication fittings are provided, to allow the user to periodically replenish the grease, as recommended by the bearing and/or grease manufacturer.

^⑦Not available.

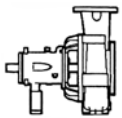

BEARING INSTALLATION FOR POWER END ASSEMBLY (CONT'D)

Both bearings have a slight interference fit which requires that they be pressed on the shaft with an arbor or hydraulic press. A chart giving bearing fits is shown in Figure 18. Even force should be applied to the inner race only. Never press on the outer race, as the force will damage the balls and races. An alternate method of installing bearings is to heat the bearings to 200°F (93°C) in an oven or induction heater. Then place them quickly in position on the shaft.

CAUTION

Never heat the bearings above 230°F (110°C). To do so will likely cause the bearing fits to permanently change, leading to early failure.

		Group 1	Group 2	Group 3
OB brg/shaft	Bearing Shaft	1.1811/1.1807	1.9685/1.9680	2.7559/2.7553
	Fit	1.1816/1.1812 0.0009T/0.0001T	1.9690/1.9686 0.0010T/0.0001T	2.7565/2.7560 0.0012T/0.0001T
IB brg/shaft	Bearing Shaft	1.3780/1.3775	1.9685/1.9680	2.7559/2.7553
	Fit	1.3785/1.3781 0.0010T/0.0001T	1.9690/1.9686 0.0010T/0.0001T	2.7565/2.7560 0.0012T/0.0001T
OB brg/hsg	Bearing Housing	2.8346/2.8341	4.3307/4.3301	5.9055/5.9047
	Fit	2.8346/2.8353 0.0012L/0.0000L	4.3310/4.3316 0.0015L/0.0003L	5.9056/5.9067 0.0020L/0.0001L
IB brg/hsg	Bearing Housing	2.8346/2.8341	4.3307/4.3301	5.9055/5.9047
	Fit	2.8346/2.8353 0.0012L/0.0000L	4.3310/4.3316 0.0015L/0.0003L	5.9058/5.9065 0.0018L/0.0003L

FIGURE 19 – Bearing Fits

- Place the snap ring (#201C) or the bearing retainer (#201D) onto the outboard end of the shaft and slide down to the inboard bearing. Note the proper orientation of the bearing retainer or snap ring must be assured in this step. The flat side of the snap ring and the small side of the retainer must face away from the inboard bearing.

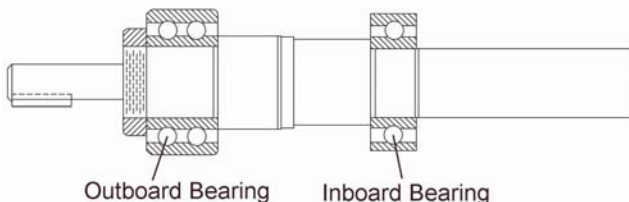

FIGURE 20 – Bearing Designations

- Using clean gloves, install the outboard bearing (#121) firmly against the shoulder as shown in

Figure 19. If hot bearing mounting techniques are used, steps must be taken to ensure the outboard bearing is firmly positioned against the shaft shoulder. The outboard bearing, while still hot, is to be positioned against the shaft shoulder. After the bearing has cooled below 100°F (38°C) the bearing should be pressed against the shaft shoulder. An approximate press force needed to seat the bearing is listed in Figure 19. This value may be used if the press has load measuring capability.

CAUTION

It must be understood that fixtures and equipment used to press the bearing must be designed so no load is ever transmitted through the bearing balls. This would damage the bearing.

The locknut (#124) and lock washer (#125) should be installed. The locknut should be torqued to the value shown in Figure 21. At this point the lock washer tang must be bent into the locknut.

Pump	Press Force lbf (N)	Locknut Torque ft•lbf (N•m)
Group 1	1300 (5,780)	20 +5/-0 (27 +4/-0)
Group 2	2500 (11,100)	0 +5/-0 (54 +7/-0)
Group 3	4500 (20,000)	70 +5/-0 (95 +7/-0)

FIGURE 21 – Bearing Press Force

- If the outboard bearing is cold pressed against the shaft shoulder, it should be secured with the lock washer and locknut torqued with the “locknut torque” value listed in Figure 21. The lockwasher tang must then be bent into the locknut.

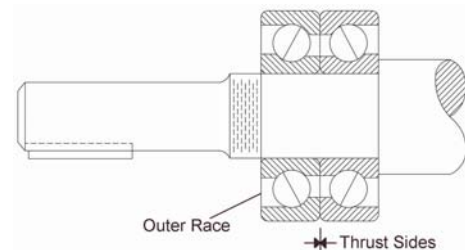
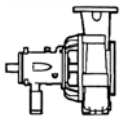

FIGURE 22 – Duplex Angular Contact Bearings

- Duplex angular contact bearings must be mounted back to back with the wider thrust sides of the outer races in contact with each other as shown in Figure 22. Only bearings designed for



universal mounting should be used. SKF's designation is "BECB". NTN's designation is "G".

Note: A special shaft is required when using duplex angular contact bearings.

LIP SEALS

If lip seals were used, install new lip seals in the bearing carrier (#201) and the housing (#119) (Group 1) or the adapter (#108) (Group 2 and 3). The lip seals (#118 and #129) are double lip style, the cavity between the lips should be 1/2 to 2/3 filled with grease.

LABYRINTH SEALS

Refer to Appendix E.

MAGNETIC SEALS

Follow the installation instructions provided by the manufacturer.

BEARING CARRIER/POWER END ASSEMBLY

6. Install new O-rings (#201B) onto the bearing carrier. Be sure to use the correct size O-rings. Slide the bearing carrier (#201) over the outboard bearing (#121).
7. On Group 1 and 2 pumps, if standard outboard bearings are used, slide the snap ring (#201C) in place with its flat side against the outboard bearing and snap it into its groove in the bearing carrier.



Never compress the snap ring unless it is positioned around the shaft and between the bearings. In this configuration, it is contained therefore if it should slip off the compression tool it is unlikely to cause serious injury.

8. On Group 1 and 2 pumps, if duplex angular contact bearings are used, slide the bearing retainer (#201D) in place, install, and tighten the socket head cap screws (#201E). See Figure 21 for correct torque values.
9. On Group 3 pumps slide the bearing retainer (#201D) against the outboard bearing and install and tighten the socket head cap screws (#201E). See Figure 21 for correct torque values.
10. The shaft, bearings, and bearing carrier assembly can now be installed into the bearing housing (#119). The bearing carrier (#201) should be lubricated with oil on the O-rings and threads before installing the assembly into the

bearing housing. Thread the bearing carrier into the bearing housing by turning it clockwise to engage the threads. Thread the carrier onto the housing until the carrier flange is approximately 1/8 in (3 mm) from the housing. Install the set screws (#201A) loosely.

11. Install a sight gage (#200) into the bearing housing.
12. If one was present, install a Trico oiler (#133) into the bearing housing. If not used, install a plug into the hole. When using a Trico oiler it is very important that a vent/breather be installed in the tapped hole on top of the bearing housing.
13. Install a drain plug (#134) into the bearing housing. Be sure to install the optional magnetic drain plug (#134M), if appropriate.
14. On Group 2 and 3 pumps, assemble the bearing housing adapter (#108) to the bearing housing (#119). Be sure to install a new O-ring (#131). Thread the cap screws (#139) through the adapter and into the tapped holes in the bearing housing.
15. If the pump has lip seals, install the deflector (#114).
16. If the pump is equipped with a hook type sleeve (#177), slip it into place over the impeller end of the shaft (#105).

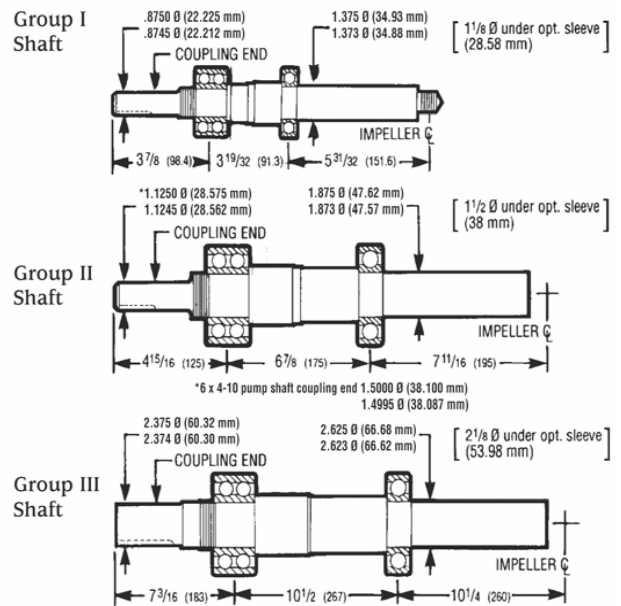
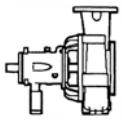

FIGURE 23 – Shaft Details

WET END ASSEMBLY

CARTRIDGE MECHANICAL SEALS

Seal installation



Slide the cartridge seal (#153) onto the shaft using a seal guide until it lightly touches the bearing housing (#119) or adapter (#108).

Rear cover plate installation

Install the rear cover plate (#106) to the bearing housing (Group 1) or the bearing housing adapter (Group 2 and 3) by using the cap screws (#140). Now install the cartridge seal gland to the rear cover plate (#106) using studs (#111) and nuts (#111A).

Impeller installation and clearance setting

Install the impeller (#103) as instructed in Appendix C, if reverse vane, or Appendix D, if a front vane open style impeller (See Figure 24). Care should be taken in the handling of high chrome iron impellers.

Lock seal in place

Tighten set screws on the seal to lock the rotating unit to the shaft. Finally, remove centering clips from the seal.

COMPONENT TYPE MECHANICAL SEAL

Determination of seal location

In order to properly set a component seal it is necessary to first locate the shaft in its final axial position. This is accomplished in the following manner.

Install the rear cover plate (#106) to the bearing housing (Group 1) or the bearing housing adapter (Group 2 and 3) by using the cap screws (#140). Install the impeller (#103) as instructed in Appendix B, if reverse vane, or Appendix C, if a front vane open style impeller. Put blueing on the shaft in the area near the face of the seal chamber (rear cover #106). Scribe a mark on the shaft at the face of the seal chamber. Now the location of the seal can be determined by referring to the seal drawing supplied by the seal manufacturer.

Impeller/rear cover removal

Remove the impeller following instructions given in the "Disassembly" section on Page 24. Remove the rear cover following instructions given in the "Disassembly" section on Page 25.

Gland installation

Install the gland (#190) and stationary seal components following the seal manufacturers instructions. Slide the gland and stationary seal components onto the shaft until it lightly touches the bearing housing or adapter. Install the gland gasket (#190G) into the gland.

Seal installation

Install the rotating unit onto the shaft (or sleeve) using a seal guide following the seal manufacturers instructions.

Rear cover plate installation

Install the rear cover plate (#106) to the bearing housing

(Group 1) or the bearing housing adapter (Group 2 and 3) by using the cap screws (#140). Now, install the gland (#190) to the rear cover plate (#106) using studs (#111) and nuts (#111A).



FIGURE 24 – Impeller Styles

Impeller final installation

Install the impeller (#103) as instructed in Appendix B, if reverse vane, or Appendix C, if a front vane open style impeller. Remember that the impeller clearance is already set. It cannot be changed at this point without resetting the seal.

PACKING WITH SPLIT GLAND

Rear cover plate installation

Install the rear cover plate (#106) to the bearing housing (Group 1) or the bearing housing adapter (Group 2 and 3) by using the cap screws (#140).

Impeller installation and clearance setting

Install the impeller (#103) as instructed in Appendix C, if reverse vane, or Appendix D, if a front vane open style impeller. Care should be taken in the handling of high chrome iron impellers.

Packing/gland installation

Install the packing rings (#113) and seal cage halves (#112) into the stuffing box as shown in Figure 7. Always stagger the end gaps 90° to ensure a better seal. To speed installation of each ring, have an assistant turn the pump shaft in one direction. This movement of the shaft will tend to draw the rings into the stuffing box. A split gland (#110) is an assembly of two matched gland halves that are bolted together. Unbolt the gland halves and install the gland halves around the shaft. Bolt the

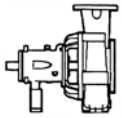

halves together to form a gland assembly. Now, install the gland assembly (#110) using studs (#111) and nuts (#111A). Lightly snug up the gland. Final adjustments must be made after the pump has begun operation.

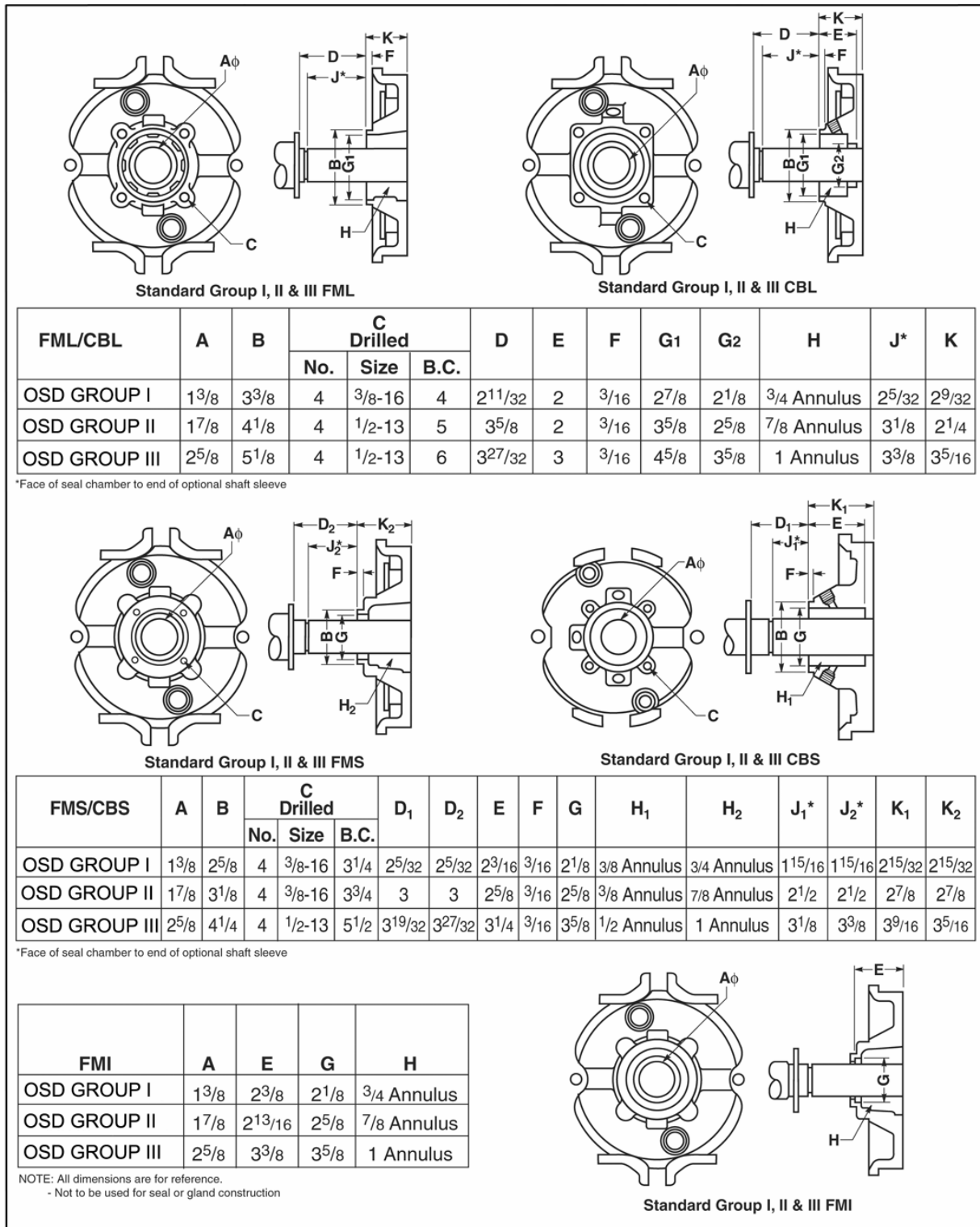
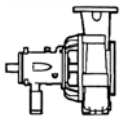
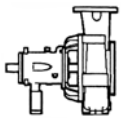

FIGURE 25 – Seal Chamber Details



PACKING WITH ONE PIECE GLAND

Gland installation

Slip gland over shaft and slide back to the bearing housing.

Rear cover plate installation

Install the rear cover plate (#106) to the bearing housing (Group 1) or the bearing housing adapter (Group 2 and 3) by using the cap screws (#140).

Impeller installation and clearance setting

Install the impeller (#103) as instructed in Appendix C, if reverse vane, or Appendix D, if a front vane open style impeller. Low-Flo impeller clearances are set off the casing, just like the standard front vane open style impeller. Refer to Appendix D for instructions on how to install, remove, and set this impeller.

Packing installation

Install the packing rings (#113) and seal cage halves (#112) into the stuffing box as shown in Figure 7. Always stagger the end gaps 90° to ensure a better seal. To speed installation of each ring, have an assistant turn the pump shaft in one direction. This movement of the shaft will tend to draw the rings into the stuffing box. Now, attach the gland (#110) to the cover using studs (#111) and nuts (#111A). Lightly snug up the gland. Final adjustments must be made after the pump has begun operation.

BEARING LUBRICATION

OIL BATH

The standard bearing housing bearings are oil bath lubricated and are not lubricated by American-Marsh. Before operating the pump, fill the bearing housing to the center of the oil sight glass with the proper type oil. (See Figure 26 for approximate amount of oil required – do not overfill.) On the OSD design, an optional oil slinger is available. The oil slinger is not necessary; however, if used, it provides an advantage by allowing a larger tolerance in acceptable oil level. Without an oil slinger, the oil level in the bearing housing must be maintained at ±1/8 in (±3 mm) from the center of the sight glass. The sight glass has a 1/4 in (6 mm) hole in the center of its reflector. The bearing housing oil level must be within the circumference of the center hole to ensure adequate lubrication of the bearings.

Pump	OSD Oil Capacity
Group 1	8.5 oz (251 ml)
Group 2	32 oz (946 ml)
Group 3	48 oz (1419 ml)

FIGURE 26 – Amount Of Oil Required

Mineral Oil	Quality mineral oil with rust and oxidation inhibitors. Mobil DTE Heavy/Medium ISO VG 68 or equivalent.
Synthetic	Royal Purple SynFilm 68, Conoco SYNCON 68 or equivalent. Some synthetic lubricants require Viton O-rings.
Grease	Royal Purple NLGI #2, Chevron SRI #2 (or compatible)

FIGURE 27 – Recommended Lubricants

Maximum Oil Temperature	ISO Viscosity Grade	Minimum Viscosity Index
Up to 160°F (71°C)	46	95
160-175°F (71°-80°C)	68	95
175-200°F (80°-94°C)	100	95

FIGURE 28 – Oil Viscosity Grades

See Figure 27 for recommended lubricants. DO NOT USE DETERGENT OILS. The oil must be free of water, sediment, resin, soaps, acid and fillers of any kind. It should contain rust and oxidation inhibitors. The proper oil viscosity is determined by the bearing housing operating temperature as given in Figure 28. To add oil to the housing, clean and then remove the vent plug (#135) at the top of the bearing housing, pour in oil until it is visually half way up in the sight glass (#200). Fill the constant level oiler bottle (Trico), if used, and return it to its position. The correct oil level is obtained with the constant level oiler in its lowest position, which results in the oil level being at the top of the oil inlet pipe nipple, or half way up in the sight glass window. Oil must be visible in the bottle at all times. Note that on OSD PLUS power ends there is no Trico oiler. As stated above, proper oil level is the center of the “bull’s eye” sight glass (#200).

Lubrication	Temperature
Oil bath	180°F* (82°C)
Oil mist	180°F* (82°C)
Grease	200°F* (94°C)

* Assuming good maintenance and operation practices, and no contamination.

** May be increased to 36 months with OSD PLUS power end.

FIGURE 29 – Maximum External Housing Temperature

In many pumping applications lubricating oil becomes contaminated before it loses its lubricating qualities or breaks down. For this reason it is recommended that

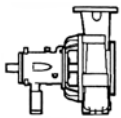

the first oil change take place after approximately 160 hours of operation, at which time, the used oil should be examined carefully for contaminants. During the initial operating period monitor the bearing housing operating temperature. Record the external bearing housing temperature. See Figure 29 for maximum acceptable temperatures. The normal oil change interval is based on temperature and is shown in Figure 31.

GREASE

Single shielded re-greasable bearings

When the grease lubrication option is specified, single shielded bearings, grease fittings and vent pipe plugs are installed inboard and outboard. The bearings are packed with Royal Purple NLGI #2 grease prior to assembly. For initial lubrication, apply grease through the fittings until it comes out of the vent holes, then reinstall the pipe plugs. See Figure 30 for initial lubrication of duplex bearing option. For re-lubrication, a grease with the same type base (non-soap polyuride) and oil (mineral) should be used. To re-grease, remove the pipe plug from both the inboard and outboard bearing location.



To re-grease bearings under coupling guard, stop pump, lock the motor, remove coupling guard, then re-grease the bearings.

Bearings configured as shown in Figure 16 will draw grease across the shield as needed.

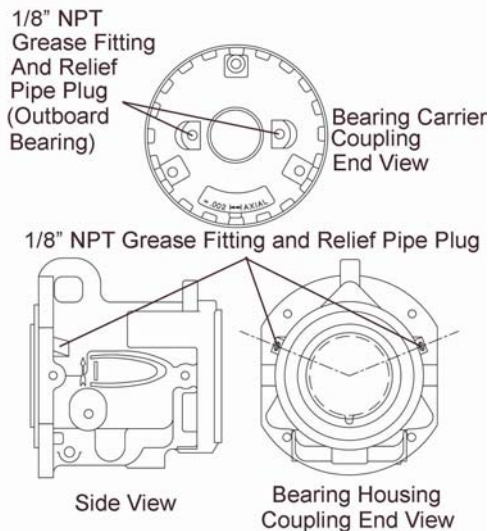

FIGURE 30 – Re-greaseable Configuration

Lubricant	Under 160°F (71°C)	160-175°F (71-80°C)	175-200°F (80-94°C)
Grease	6 mo	3 mo	1.5 mo
Mineral Oil	6 mo	3 mo	1.5 mo
Synthetic Oil**	18 mo	18 mo	18 mo

FIGURE 31 – Re-lubrication Intervals

Housing Location	Initial Lube	Re-lubrication
Group 1 Inboard	till grease comes out plug hole	6 g
Group 1 Outboard	till grease comes out plug hole	11 g
Group 1 Duplex	30 g	15 g
Group 2 Inboard	till grease comes out plug hole	15 g
Group 2 Outboard	till grease comes out plug hole	25 g
Group 2 Duplex	60 g	30 g
Group 3 Inboard	till grease comes out plug hole	26 g
Group 3 Outboard	till grease comes out plug hole	48 g
Group 3 Duplex	100 g	53 g

FIGURE 32 – Amount of Grease Required

Notes:

1. Royal Purple NLGI #2 grease density = 0.92 g/cm³.
2. Grams to ounces conversion: g * 0.035 = oz.
3. Typical tube of grease holds 14 oz (397 g).
4. Grease reservoirs should be cleaned out every 18 months and new initial lube amount applied.



Do not fill the housing with oil when greased bearings are used. The oil will leach the grease out of the bearings and the life of the bearings may be drastically reduced.

Double shielded or double sealed bearings

These bearings are packed with grease by the bearing manufacturer and should not be re-lubricated. Maintenance intervals for these bearings are greatly affected by their operating temperature and pump speed. However, the shielded bearing typically operates cooler, thus extending its life.

OIL MIST

When optional oil mist lubricated bearings are specified, the bearing housing is furnished with a plugged 1/2 in NPT top inlet for connection to the user's oil mist supply system, a vent fitting in the bearing carrier, and a plugged 1/4 in NPT bottom drain. See Oil Mist Lubrication System on Page 15.

Do not allow oil level to remain above the center of the bearing housing sight glass window with purge mist (wet sump) systems.

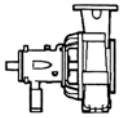

The optional oil slinger must not be used with an oil mist system.

REINSTALLATION

The pump is now ready to be returned to service. It should be reinstalled as described in the installation section.

SPARE PARTS

RECOMMENDED SPARE PARTS – STANDARD OSD PUMP

The decision on what spare parts to stock varies greatly depending on many factors such as the criticality of the application, the time required to buy and receive new spares, the erosive/corrosive nature of the application, and the cost of the spare part. Figures 33, 34, 35 & 36 give the parts list for a typical OSD pump. Please refer to the “American-Marsh Pump Parts Catalog” for more information. Prior to resizing impellers in high chrome iron and nickel, please consult your local American-Marsh sales representative.

HOW TO ORDER SPARE PARTS

Spare parts can be ordered from the local American-Marsh Sales Engineer, or from the American-Marsh Distributor or Representative. The pump size and type can be found on the name plate on the bearing housing. See Figure 3. Please provide the item number, description, and alloy for the part(s) to be ordered.

To make parts ordering easy, American-Marsh has created a catalog titled “American-Marsh Pump Parts Catalog.” A copy of this book can be obtained from the local American-Marsh Sales Engineer or Distributor/Representative.

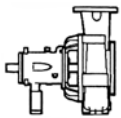
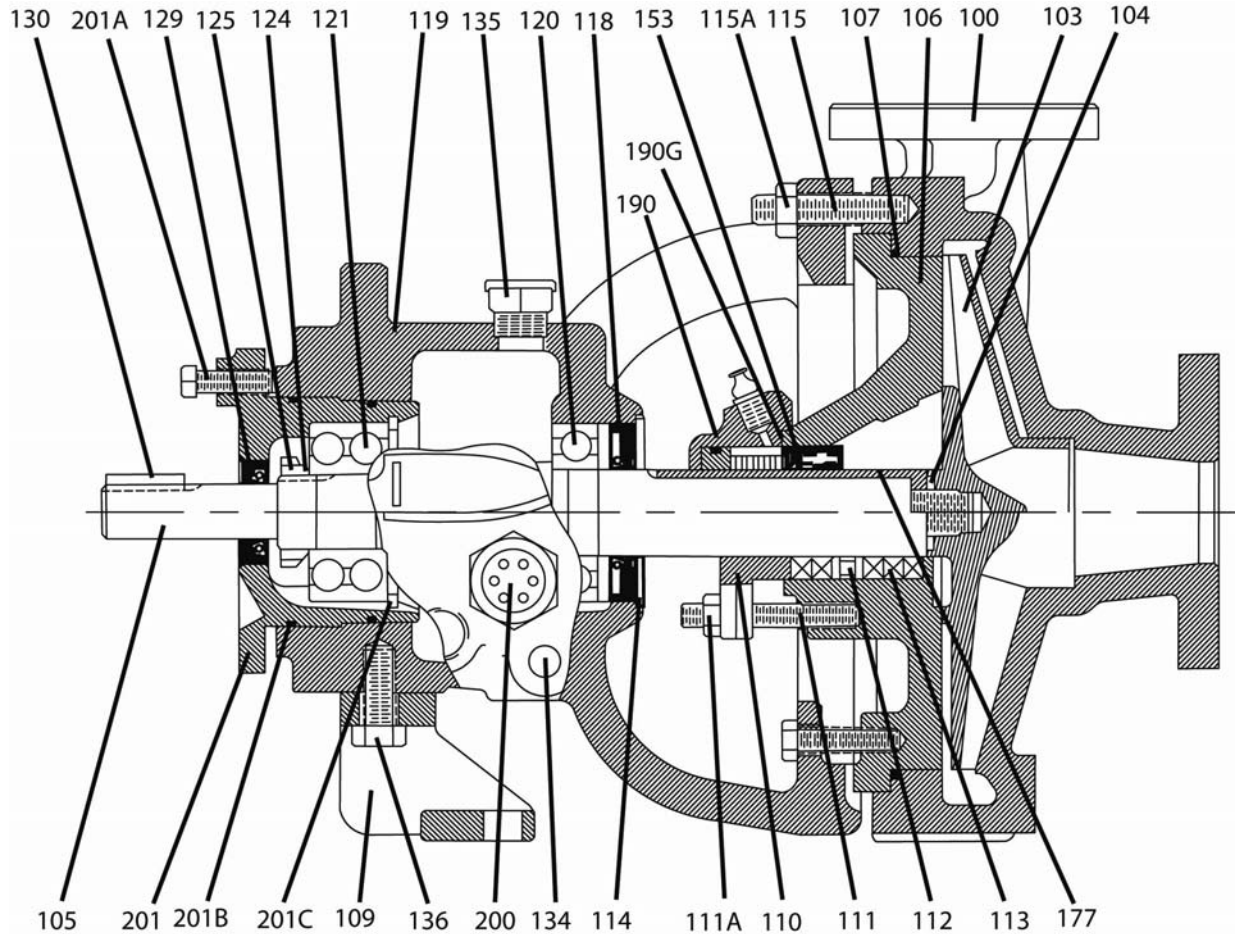

FIGURE 33 – Group 1 Sectional Drawing



Item Number	Item Description	
100	Casing	
103	Impeller	
104	Impeller Gasket	
105	Shaft	
106	Rear Cover Plate	
107	Rear Cover Gasket	
108	Bearing Housing Adapter	N/A
109	Bearing Housing Foot	
109A	Shim	
110	Gland – Packing	OPT.
111	Stud – Gland	
111A	Hex Nut – Gland	
112	Lantern Ring Halves	OPT.
113	Packing	OPT.
114	Inboard Deflector	OPT.
115	Stud – Casing	
115A	Hex Nut – Casing	
118	Inboard Oil Lip Seal	
119	Bearing Housing	
120	Inboard Bearing	
121	Outboard Bearing	
122	Oil Slinger	OPT.

Item Number	Item Description	
124	Bearing Locknut	
125	Bearing Lockwasher	
129	Outboard Oil Lip Seal	
131	Adapter O-Ring	N/A
133	Trico Oiler	
134	Bearing Housing Drain Plug	
135	Bearing Housing Vent Plug	
136	Capscrew – Foot	
139	Capscrew – Bearing Housing	N/A
140	Capscrew – Cover/Adapter	
153	Mechanical Seal	
177	Hook Sleeve	OPT.
190	Gland – Mechanical Seal	
190G	Gland Gasket	
200	Oil Sight Gage	
201	Bearing Carrier	
201A	Set Screw – Bearing Carrier	
201B	O-Ring – Bearing Carrier	
201C	Bearing Carrier Retainer	
201D	Clap Ring Bearing Housing	OPT.
201E	Socket Head Capscrew Clamp	OPT.

Recommended spare parts are in BOLD.

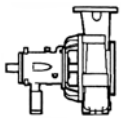
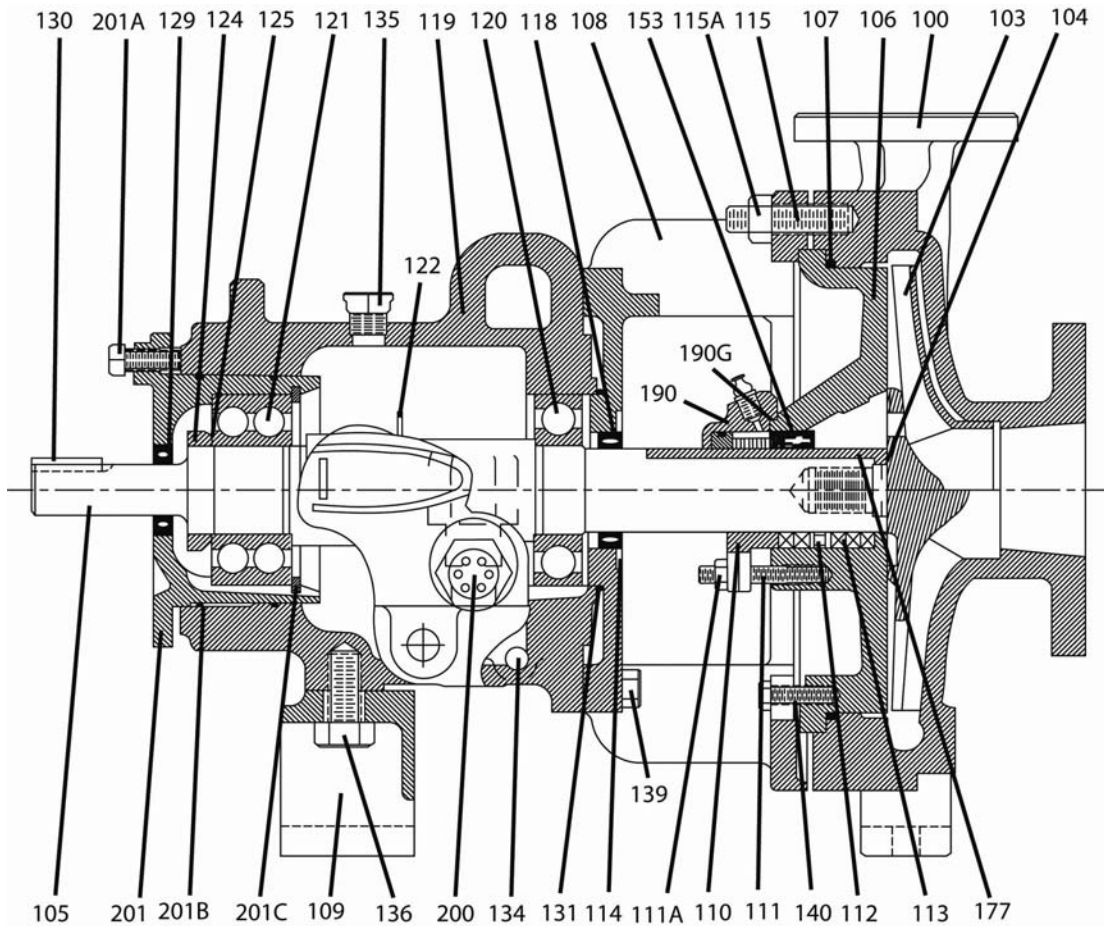

FIGURE 34 – Group 2 Sectional Drawing



Item Number	Item Description	
100	Casing	
103	Impeller	
104	Impeller Gasket	
105	Shaft	
106	Rear Cover Plate	
107	Rear Cover Gasket	
108	Bearing Housing Adapter	
109	Bearing Housing Foot	
109A	Shim	
110	Gland – Packing	OPT.
111	Stud – Gland	
111A	Hex Nut – Gland	
112	Lantern Ring Halves	OPT.
113	Packing	OPT.
114	Inboard Deflector	OPT.
115	Stud – Casing	
115A	Hex Nut – Casing	
118	Inboard Oil Lip Seal	
119	Bearing Housing	
120	Inboard Bearing	
121	Outboard Bearing	
122	Oil Slinger	OPT.

Item Number	Item Description	
124	Bearing Locknut	
125	Bearing Lockwasher	
129	Outboard Oil Lip Seal	
131	Adapter O-Ring	
133	Trico Oiler	
134	Bearing Housing Drain Plug	
135	Bearing Housing Vent Plug	
136	Capscrew – Foot	
139	Capscrew – Bearing Housing	N/A
140	Capscrew – Cover/Adapter	
153	Mechanical Seal	
177	Hook Sleeve	OPT.
190	Gland – Mechanical Seal	
190G	Gland Gasket	
200	Oil Sight Gage	
201	Bearing Carrier	
201A	Set Screw – Bearing Carrier	
201B	O-Ring – Bearing Carrier	
201C	Bearing Carrier Retainer	
201D	Clap Ring Bearing Housing	OPT.
201E	Socket Head Capscrew Clamp	OPT.

Recommended spare parts are in BOLD.

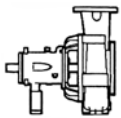
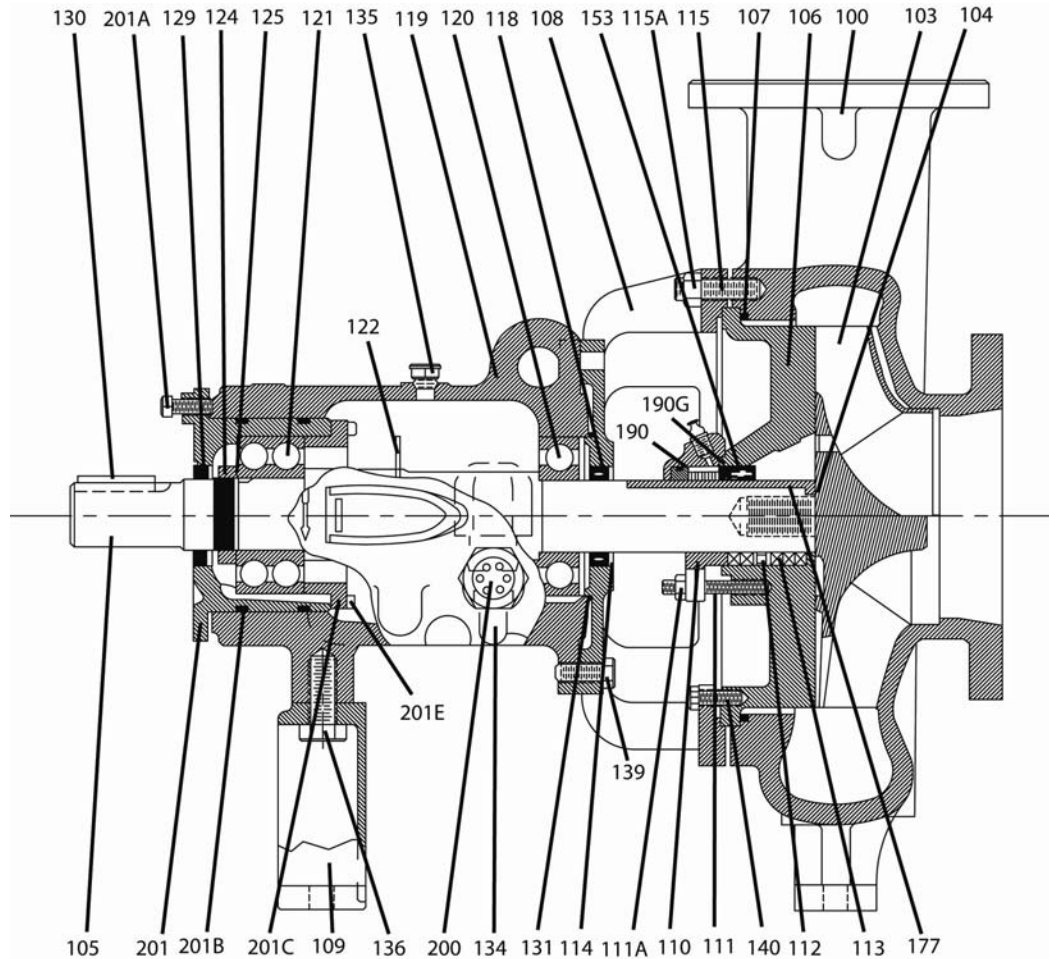

FIGURE 35 – Group 3 Sectional Drawing



Item Number	Item Description	
100	Casing	
103	Impeller	
104	Impeller Gasket	
105	Shaft	
106	Rear Cover Plate	
107	Rear Cover Gasket	
108	Bearing Housing Adapter	
109	Bearing Housing Foot	
109A	Shim	
110	Gland – Packing	OPT.
111	Stud – Gland	
111A	Hex Nut – Gland	
112	Lantern Ring Halves	OPT.
113	Packing	OPT.
114	Inboard Deflector	OPT.
115	Stud – Casing	
115A	Hex Nut – Casing	
118	Inboard Oil Lip Seal	
119	Bearing Housing	
120	Inboard Bearing	
121	Outboard Bearing	
122	Oil Slinger	OPT.

Item Number	Item Description	
124	Bearing Locknut	
125	Bearing Lockwasher	
129	Outboard Oil Lip Seal	
131	Adapter O-Ring	
133	Trico Oiler	
134	Bearing Housing Drain Plug	
135	Bearing Housing Vent Plug	
136	Capscrew – Foot	
139	Capscrew – Bearing Housing	N/A
140	Capscrew – Cover/Adapter	
153	Mechanical Seal	
177	Hook Sleeve	OPT.
190	Gland – Mechanical Seal	
190G	Gland Gasket	
200	Oil Sight Gage	
201	Bearing Carrier	
201A	Set Screw – Bearing Carrier	
201B	O-Ring – Bearing Carrier	
201C	Bearing Carrier Retainer	
201D	Clap Ring Bearing Housing	
201E	Socket Head Capscrew Clamp	

Recommended spare parts are in **BOLD**.

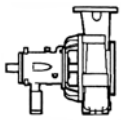

APPENDIX A

CRITICAL MEASUREMENTS AND TOLERANCES FOR MAXIMIZING MTBPM

PARAMETERS THAT SHOULD BE CHECKED BY USERS

American-Marsh recommends that the user check the following measurements and tolerances whenever pump maintenance is performed. Each of these measurements is described in more detail on the following pages.

Topic	ASME B73.1M Std. in (mm)	Suggested By Major Seal Vendors in (mm)	Suggested And/Or Provided By AMP in (mm)
Shaft			
Diameter tolerance, under bearings	N.S.		0.0002 (0.005)
Impeller			
Balance			See Note 1
Bearing Housing			
Diameter (ID) tolerance at bearings	N.S.		0.0005 (0.013)
Power End Assembly			
Shaft Runout	0.002 (0.05)	0.001 (0.03)	0.001 (0.03)
Shaft Sleeve Runout	0.002 (0.05)	0.002 (0.05)	0.002 (0.05)
Radial Deflection - Static	N.S.	0.003 (0.076)	0.002 (0.05)
Shaft Endplay	N.S.	0.002 (0.05)	0.002 (0.05)
Seal Chamber			
Face Squareness to Shaft	0.003 (0.08)	0.001 (0.03)	0.003 (0.08)
Register Concentricity	0.005 (0.13)	0.005 (0.13)	0.005 (0.13)
Complete Pump			
Shaft movement caused by pipe strain	N.S.	0.002 (0.05)	0.002 (0.05)
Alignment	N.S.		See Note 2
Vibration at bearing housing	0.25 in/s (6.3 mm/s)		See Note 3

FIGURE 36 - Measurements

N.S. = Not specified

Note 1: The maximum values of acceptable unbalance are: 1800 rpm: 0.021 oz•in/lb (1500 rpm: 40 g•mm/kg) of mass; 3600 rpm: 0.011 oz•in/lb (2900 rpm: 20 g•mm/kg) of mass. American-Marsh performs a single plane spin balance on most impellers. The following impellers are exceptions: 8x10-14 and 8x10-16H. On these American-Marsh performs a two plane dynamic balance, as required by the ASME B73.1M standard. All balancing, whether single or two plane, is performed to the ISO 1940 Grade 6.3 tolerance criteria.

Note 2: The ASME B73.1M standard does not specify a recommended level of alignment. American-Marsh recommends that the pump and motor shafts be aligned to within 0.002 in (0.05 mm) parallel F.I.M.

(Full Indicator Movement) and 0.0005 in/in (0.0005 mm/mm) angular F.I.M. Closer alignment will extend MTBPM. For a detailed discussion of this subject see the Alignment section of this IOM.

Note 3: The ASME B73.1M standard for vibration at the bearing housing is 0.25 in/s (6.3 mm/second) peak velocity or 0.0025 (63 μm) peak-to-peak displacement. American-Marsh recommends the following peak velocities, in in/s (mm/second): Group 1 = 0.1 (2.5), Group 2 = 0.15 (3.8), Group 3 = 0.25 (6.3).

ADDITIONAL PARAMETERS CHECKS BY AMERICAN-MARSH

The parameters listed below are somewhat more difficult to measure and/or may require specialized equipment. For this reason, they are not typically checked by our customers, although they are monitored by American-Marsh during the manufacturing and/or design process. These parameters are described at the end of this appendix.

Topic	ASME B73.1M Std.	Suggested By Major Seal Vendors	Suggested And/Or Provided By AMP
Shaft - Maximum roughness at seal chamber	32μin (0.80 μm)		16μin (0.40 μm)
Bearing Housing - Bore Concentricity			0.001 in (0.025 mm)
Complete Pump – Dynamic Shaft Deflection*	0.005 in (0.13 mm)	0.002 in (0.05 mm)	0.002 in (0.05 mm)

FIGURE 37 – Specialized Measurements

*The ASME standard recommends 0.005 in (0.13 mm) max deflection at the impeller, while American-Marsh provides 0.002 in (0.05 mm) max deflection at the mechanical seal. The two recommendations are essentially equivalent.

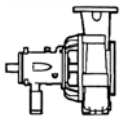

SHAFT

Before installing the shaft into the power end it is important to check the following parameters.

Diameter tolerance, under bearings

In order to ensure that the bearings fit around the shaft properly, it is important that the shaft diameter is consistently within the min/max values given below. A micrometer should be used to check the dimension of the OD of the shaft.

US Units		Group 1	Group 2	Group 3
OB brg/ shaft - in	Bearing	1.1811/1.1807	1.9685/1.9680	2.7559/2.7553
	Shaft	1.1816/1.1812	1.9690/1.9686	2.7565/2.7560
	Fit	0.0009T/0.0001T	0.0010T/0.0001T	0.0012T/0.0001T
IB brg/ shaft in	Bearing	1.3780/1.3775	1.9685/1.9680	2.7559/2.7553
	Shaft	1.3785/1.3781	1.9690/1.9686	2.7565/2.7560
	Fit	0.0010T/0.0001T	0.0010T/0.0001T	0.0012T/0.0001T

Metric Units		Group 1	Group 2	Group 3
OB brg/ shaft - mm	Bearing	30.000/29.990	50.000/49.987	70.000/69.985
	Shaft	30.013/30.003	50.013/50.003	70.015/70.002
	Fit	0.023T/0.003T	0.026T/0.003T	0.030T/0.002T
IB brg/ shaft mm	Bearing	35.000/34.989	50.000/49.987	70.000/69.985
	Shaft	35.014/35.004	50.013/50.003	70.015/70.002
	Fit	0.025T/0.004T	0.026T/0.003T	0.030T/0.002T

FIGURE 38 – Bearing/Shaft Dimensions

The ID of the bearings should also be checked and should conform to the min/max values given above.

IMPELLER BALANCING

Shaft whip is deflection where the centerline of the impeller is moving around the true axis of the pump. It is not caused by hydraulic force but rather by an imbalance with the rotating element. Shaft whip is very hard on the mechanical seal because the faces must flex with each revolution in order to maintain contact. To minimize shaft whip it is imperative that the impeller is balanced. All impellers manufactured by American-Marsh are balanced after they are trimmed. If for any reason, a customer trims an impeller, it must be re-balanced.

The maximum values of acceptable unbalance are:

1800 rpm: 0.021 oz•in/lb (1500 rpm: 40 g•mm/kg) of mass
3600 rpm: 0.011 oz•in/lb (2900 rpm: 20 g•mm/kg) of mass

American-Marsh performs a single plane spin balance on most impellers. The following impellers are exceptions: 8x10-14 and 8x10-16H. On these, a two plane dynamic balance is performed, as required by the ASME B73.1M standard. All balancing, whether single or two plane, is performed to the ISO 1940 Grade 6.3 tolerance criteria.

BEARING HOUSING

Diameter (ID) tolerance at bearings

ENGINEERED PROCESS GROUP

An inside caliper should be used to check the dimension of the ID of the housing and bearing carrier. The diameter must be within the following min/max values given in order to provide the proper bearing tightness.

The OD of the bearings should also be checked and should conform to the min/max values given above.

POWER FRAME ASSEMBLY

Shaft/Shaft Sleeve Runout

Shaft runout is the amount the shaft is “out of true” when rotated in the pump. It is measured by attaching a dial indicator to a stationary part of the pump so that its contact point indicates the radial movement of the shaft surface as the shaft is rotated slowly. If a shaft sleeve is used then shaft sleeve runout must be checked. It is analogous to shaft runout.

Measurement of shaft runout/ shaft sleeve runout will disclose any out of roundness of the shaft, any eccentricity between the shaft and the sleeve, any permanent bend in the shaft, and/or any eccentricity in the way the shaft or bearings are mounted in the bearing housing.

Shaft runout can shorten the life of the bearings and the mechanical seal. The following diagram shows how to measure shaft/shaft sleeve runout. Note that both ends need to be checked. The runout should be 0.001 in (0.025 mm) FIM or less.

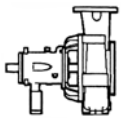

US Units		Group 1	Group 2	Group 3
OB brg/ shaft - mm	Bearing	2.8346/2.8341	4.3307/4.3301	5.9055/5.9047
	Hsg	2.8346/2.8353	4.3310/4.3316	5.9056/5.9067
	Fit	0.0012L/0.0000L	0.0015L/0.0003L	0.0020L/0.0001L
IB brg/ shaft mm	Bearing	2.8346/2.8341	4.3307/4.3301	5.9055/5.9047
	Hsg	2.8346/2.8353	4.3310/4.3316	5.9058/5.9065
	Fit	0.0012L/0.0000L	0.0015L/0.0003L	0.0018L/0.0003L

Metric Units		Group 1	Group 2	Group 3
OB brg/ shaft - mm	Bearing	71.999/71.986	110.000/109.985	150.000/149.979
	Hsg	71.999/72.017	110.007/110.022	150.002/150.030
	Fit	0.031L/0.000L	0.037L/0.007L	0.051L/0.002L
IB brg/ shaft mm	Bearing	71.999/71.986	110.000/109.985	150.000/149.979
	Hsg	71.999/72.017	110.007/110.022	150.007/150.025
	Fit	0.031L/0.000L	0.037L/0.007L	0.046L/0.007L

FIGURE 39 – Bearing Housing Tolerances

Radial Deflection – Static

Radial movement of the shaft can be caused by a loose fit between the shaft and the bearing and/or the bearing and the housing. This movement is measured by attempting to displace the shaft vertically by applying an upward force of approximately ten pounds to the impeller end of the shaft. While applying this force, the movement of an indicator is observed as shown in the following diagram. The movement should be checked at a point as near as possible to the location of the seal faces. A movement of more than 0.002 in (0.05 mm) is not acceptable.

Shaft Endplay

The maximum amount of axial shaft movement, or endplay, on an American-Marsh pump should be 0.001 in (0.03 mm) and is measured as shown below. Observe indicator movement while tapping the shaft from each end in turn with a soft mallet. Shaft endplay can cause several problems. It can cause fretting or wear at the point of contact between the shaft and the secondary sealing element. It can also cause seal overloading or underloading and possibly chipping of the seal faces. It can also cause the faces to separate if significant axial vibration occurs.

SEAL CHAMBER

Face Squareness to Shaft

Also referred to as “Seal Chamber Face Run-Out.” This runout occurs when the seal chamber face is not perpendicular to the shaft axis. This will cause the gland to cock, which causes the stationary seat to be cocked, which causes the seal to wobble. This runout should be less than 0.003 in (0.08 mm) and should be measured as shown below:

Register Concentricity

An eccentric seal chamber bore or gland register can interfere with the piloting and centering of the seal components and alter the hydraulic loading of the seal

faces, resulting in reduction of seal life and performance. The seal chamber register concentricity should be less than 0.005 in (0.13 mm). The diagram below shows how to measure this concentricity.

COMPLETE PUMP

Shaft Movement Caused by Pipe Strain

Pipe strain is any force put on the pump casing by the piping. Pipe strain should be measured as shown below. Install the indicators as shown before attaching the piping to the pump. The suction and discharge flanges should now be bolted to the piping separately while continuously observing the indicators. Indicator movement should not exceed 0.002 in (0.05 mm).

Alignment

Misalignment of the pump and motor shafts can cause the following problems:

- Failure of the mechanical seal
- Failure of the motor and/or pump bearings
- Failure of the coupling
- Excessive vibration/noise

The schematics below show the technique for a typical rim and face alignment using a dial indicator. It is important that this alignment be done after the flanges are loaded, and at typical operating temperatures. If proper alignment cannot be maintained a C-flange motor adapter and/or stilt/spring mounting should be considered.

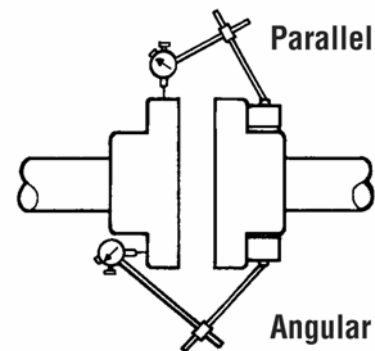
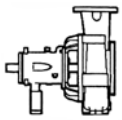

FIGURE 40 – Alignment

Many companies today are using laser alignment which is a more sophisticated and accurate technique. With this method a laser and sensor measure misalignment. This is fed to a computer with a graphic display which shows the required adjustment for each of the motor feet.

Vibration Analysis

Vibration Analysis is a type of condition monitoring where a pump’s vibration “signature” is monitored on a regular, periodic basis. The primary goal of vibration analysis is extension on MTBPM. By using this tool American-Marsh can often determine not only the



existence of a problem before it becomes serious, but also the root cause and possible the solution. Modern vibration analysis equipment not only detects if a vibration problem exists, but can also suggest the cause of the problem. On a centrifugal pump, these causes can include the following: unbalance, misalignment, defective bearings, resonance, hydraulic forces, cavitation, and recirculation. Once identified, the problem can be corrected, leading to increased MTBPM for the pump.

American-Marsh does not make vibration analysis equipment, however American-Marsh strongly urges customers to work with an equipment supplier or consultant to establish an on-going vibration analysis program. The ASME standard for vibration at the bearing housing is 0.25 inches/second (6.35 mm/sec) peak velocity or 0.0025 inches (0.064 mm) peak-to-peak displacement. American-Marsh recommends the following peak velocities:

- Group 1 0.1 in/s (2.5 mm/s)
- Group 2 0.15 in/s (3.8 mm/s)
- Group 3 0.25 in/s (6.4 mm/s)

for best practice of a properly installed and operated pump.

SPECIAL PARAMETERS CHECKED BY AMERICAN-MASH

SHAFT – MAXIMUM ROUGHNESS AT SEAL CHAMBER

The ASME B73.1M standard requires that the surface finish of the shaft (or sleeve) through the stuffing box and at rubbing contact bearing housing seals shall not exceed a roughness of 32 μ in (0.8 μ m). American-Marsh shafts do not exceed 16 μ in (0.4 μ m) at these areas. American-Marsh audits smoothness by using a profilometer surface finish gauge.

BEARING HOUSING – BORE CONCENTRICITY

If the bore for holding the bearing is eccentric, the bearing will be shifted off center. This will contribute to shaft runout. American-Marsh measures this concentricity by using computerized measuring equipment. The concentricity should not exceed 0.001 in (0.03 mm).

COMPLETE PUMP – DYNAMIC SHAFT DEFLECTION

In regards to pump operation, a very important factor for maximizing pump MTBPM is the avoidance of off-design pump operation. In order to maximize the life of the seal

and bearings, a process pump should be run as close as possible to its Best Efficiency Point (BEP).

Dynamic shaft deflection is a deflection of the shaft caused by unbalanced hydraulic forces acting on the impeller. Dynamic shaft deflection will change as the pump is operated on various points along the curve. When the pump is operated at BEP, the shaft deflection is zero. This deflection is very difficult to measure. The ASME B73.1M standard states that dynamic shaft deflection at the impeller centerline shall not exceed 0.005 in (0.13 mm) at maximum load (shutoff) for pump sizes A70 and smaller and at design load for pump sizes A80 and larger.

At a given point on the curve, the shaft deflection is constant and is constantly in the same direction. The centerline of the impeller, though bent from parallel, does not move. For this reason, in many cases, shaft deflection is not particularly hard on mechanical seals. It is, however, hard on bearings, since the force which causes shaft deflection can be a tremendous load on them. The amount of deflection depends on three factors: how the shaft is supported, the strength of the shaft and the amount of unbalanced hydraulic force experienced by the shaft/impeller. If there seems to be a shaft deflection problem, refer to the American-Marsh Pump Engineering Manual for a detailed discussion on how to calculate deflection.

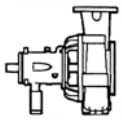

APPENDIX B

INSTALLATION/CLEARANCE SETTING FOR REVERSE VANE IMPELLER

Install the impeller (#103) by screwing it onto the shaft (use heavy gloves) until it firmly seats against the shaft shoulder.

! WARNING

The impeller could have sharp edges which could cause an injury. It is very important to wear heavy gloves.

! CAUTION

Do not attempt to tighten the impeller on the shaft by hitting the impeller with a hammer or any other object or by inserting a pry bar between the impeller vanes. Serious damage to the impeller may result from such actions.

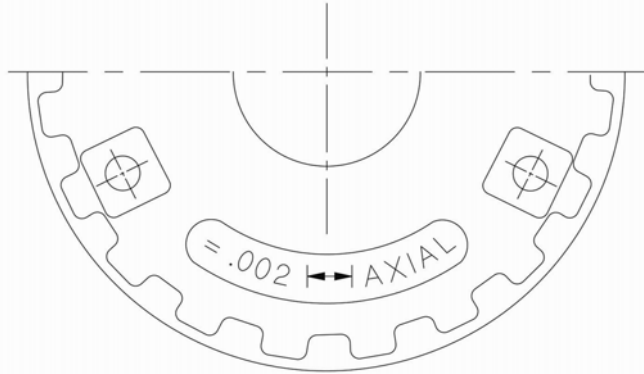

FIGURE 41 – Micro-Millimeter Adjustment

Now set the impeller clearance by loosening the set screws (#201A) and rotating the bearing carrier (#201) to obtain the proper clearance. Turn the bearing carrier counterclockwise until the impeller comes into light rubbing contact with the rear cover. Rotating the shaft at the same time will accurately determine this zero setting. Now, rotate the bearing carrier clockwise to get the proper clearance. Refer to Figure 42 for the proper impeller clearance. Rotating the bearing carrier the width of one of the indicator patterns cast into the bearing carrier moves the impeller axially 0.004 in (0.1 mm).

! CAUTION

It is recommended that two people install a Group 3 impeller. The weight of a Group 3 impeller greatly increases the chance of thread damage and subsequent lock-up concerns.

Determine how far to rotate the bearing carrier by dividing the desired impeller clearance by 0.004 (one indicator pattern). Tightening the set screws (#201A) will cause the impeller to move 0.002 in (0.05 mm) closer to the rear cover because of the internal looseness in the bearing carrier threads. This must be considered when setting the impeller clearance. Rotate the bearing carrier clockwise the required amount to get the desired clearance to the cover. Lastly, tighten the set screws (#201A) to lock the bearing carrier in place.

Temperature – °F (°C)	Clearance to cover – in (mm)
<200 (93)	0.018 ± 0.003 (0.46 ± 0.08)
200 to 250 (93 to 121)	0.021 (0.53)
251 to 300 (122 to 149)	0.024 (0.61)
301 to 350 (150 to 176)	0.027 (0.69)
351 to 400 (177 to 204)	0.030 (0.76)
401 to 450 (205 to 232)	0.033 (0.84)
>450 (232)	0.036 (0.91)

FIGURE 42 – Impeller Clearance Settings

Notes

- For 1.5x3-13 and 2x3-13 at 3500 rpm add 0.003 in (0.08 mm).
- Rotation of bearing carrier from center of one lug to center of next results in axial shaft movement of 0.004 in (0.1 mm).
- Reverse vane impeller set to cover, open impeller to casing.

Example: For an impeller setting of 0.020 in (0.5 mm) off the rear cover plate, it is necessary to add 0.002 in (0.05 mm) for the movement caused by tightening the set screws; therefore, an adjustment of 0.022 in (0.56 mm) is needed. First, turn the bearing carrier counterclockwise until the impeller comes into light rubbing contact with the rear cover. Now rotate the bearing carrier clockwise 5-1/2 indicator patterns to get the 0.022 in (0.56 mm) clearance (0.004 x 5-1/2 = 0.022). American-Marsh suggests that a felt tip pen be used to mark an initial reference point on the bearing housing and the bearing carrier as shown in Figure D-5. Then make a second mark on the bearing carrier 5-1/2 indicator patterns counterclockwise from the initial reference point. Now rotate the bearing carrier clockwise until the second mark on the bearing carrier lines up with the initial reference point mark on the bearing housing. The impeller is now set correctly.

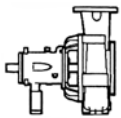

APPENDIX C

INSTALLATION/CLEARANCE SETTING FOR FRONT VANE SEMI-OPEN IMPELLER

Install the impeller (#103) by screwing it onto the shaft (use heavy gloves) until it firmly seats against the shaft shoulder.

! WARNING

The impeller could have sharp edges which could cause an injury. It is very important to wear heavy gloves.

! CAUTION

Do not attempt to tighten the impeller on the shaft by hitting the impeller with a hammer or any other object or by inserting a pry bar between the impeller vanes. Serious damage to the impeller may result from such actions.

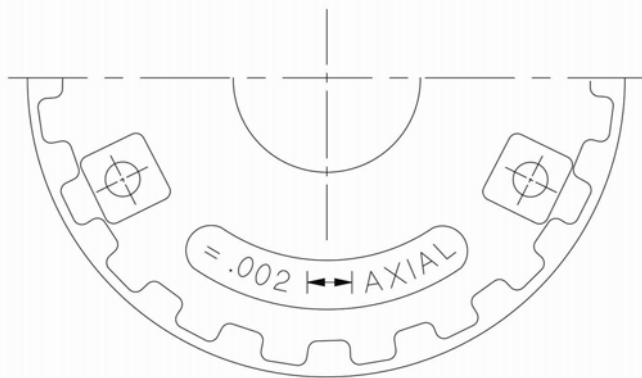

FIGURE 43 – Micro-Millimeter Adjustment

Like all front vane open style impellers, the American-Marsh semi-open impeller clearance must be set off the casing. The casing must be present to accurately set the impeller clearance. (Realizing that this can be very difficult, American-Marsh strongly promotes the use of reverse vane impellers, which do not require the presence of the casing to be properly set.)

Attach the power end/rear cover plate assembly to the casing. Now set the impeller clearance by loosening the set screws (#201A) and rotating the bearing carrier (#201) to obtain the proper clearance. Turn the bearing carrier clockwise until the impeller comes into light rubbing contact with the casing. Rotating the shaft at the

same time will accurately determine this zero setting. Now, rotate the bearing carrier counterclockwise to get the proper clearance. Refer to Figure 44 for the proper impeller clearance. Rotating the bearing carrier the width of one of the indicator patterns cast into the bearing carrier moves the impeller axially 0.004 in (0.1 mm). (See Figure 46.)

Determine how far to rotate the bearing carrier by dividing the desired impeller clearance by 0.004 in (0.1 mm) (one indicator pattern). Tightening the set screws (#201A) will cause the impeller to move 0.002 in (0.05 mm) away from the casing because of the internal looseness in the bearing carrier threads. This must be considered when setting the impeller clearance. Rotate the bearing carrier counterclockwise the required amount to get the desired clearance to the casing. Lastly, tighten the set screws (#201A) to lock the bearing carrier in place.

Temperature – °F (°C)	Clearance to cover – in (mm)
<200 (93)	0.018 ± 0.003 (0.46 ± 0.08)
200 to 250 (93 to 121)	0.021 (0.53)
251 to 300 (122 to 149)	0.024 (0.61)
301 to 350 (150 to 176)	0.027 (0.69)
351 to 400 (177 to 204)	0.030 (0.76)
401 to 450 (205 to 232)	0.033 (0.84)
>450 (232)	0.036 (0.91)

FIGURE 44 – Impeller Clearance Settings

Notes

- For 3 x 1.5-13 and 3x2-13 at 3500 rpm add 0.003 in (0.08 mm).
- Rotation of bearing carrier from center of one lug to center of next results in axial shaft movement of 0.004 in (0.1 mm).
- Reverse vane impeller set to cover, open impeller to casing.

Example: For an impeller setting of 0.020 in (0.5 mm) off the casing, it is necessary to subtract 0.002 in (0.05 mm) for the movement caused by tightening the set screws; therefore, an adjustment of 0.018 in (0.46 mm) is needed. First, turn the bearing carrier clockwise until the impeller comes into light rubbing contact with the casing. Now rotate the bearing carrier counterclockwise 4-1/2 indicator patterns to get the 0.018 in (0.46 mm) clearance ($0.004 \times 4\text{-}1/2 = 0.018$). American-Marsh suggests that a felt tip pen be used to mark an initial reference point on the bearing housing and the bearing carrier as shown in Figure E-5. Then make a second mark on the bearing carrier 4-1/2 indicator patterns clockwise from the initial reference point. Now rotate the bearing carrier counterclockwise until the second mark on the bearing carrier lines up with the initial reference point mark on the bearing housing. At that point, the setting will be 0.018 in (0.46 mm). Tightening the set screws will cause a 0.002 in (0.05 mm) draw of the bearing carrier threads, which will give the final setting of 0.020 in (0.5 mm).

The above procedure is fairly straightforward when doing the final setting of the impeller. However, it can be quite

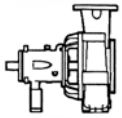

laborious when doing the preliminary setting in order to establish the location of the mechanical seal. For this reason, some companies will take the following shortcut. Before the pump is taken out of service, they adjust the impeller until it touches the casing. The impeller is then backed off by 0.020 in (0.5 mm), or whatever is the desired clearance. Now, the impeller is adjusted all the way back to the rear cover, and this distance is recorded. The pump is now removed from the casing and taken to the shop for maintenance. When it is time to set the seal, the impeller is simply set off the rear cover by the same distance recorded earlier.

Note that if the casing, cover, impeller or shaft need to be replaced this shortcut method will not work.

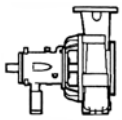

APPENDIX D

REMOVAL/INSTALLATION OF SEALS WITH FMI SEAL CHAMBER

REMOVAL

After removing the impeller, slide the hook sleeve off the shaft. Remove the rotating unit from the sleeve. Remove cover. Remove the stationary seat from the seal chamber counter bore.

INSTALLATION

1. Set the impeller as instructed in Appendix C or D.
2. Remove the impeller.
3. Install stationary seat into seal chamber counterbore.
4. Refer to Figure 45. Measure distance TL from the seal face on the stationary seat to the end of the hook sleeve.
5. The seal working length, WL, is determined from the seal drawing provided by the seal manufacturer. Subtract the seal working length WL from TL.
6. The distance remaining, RL, is the distance from the end of the hook sleeve to the rotating unit. Install the rotating unit at this location.
7. Install the hook sleeve onto the shaft.
8. Install the impeller to the shaft, locking the hook sleeve into position.

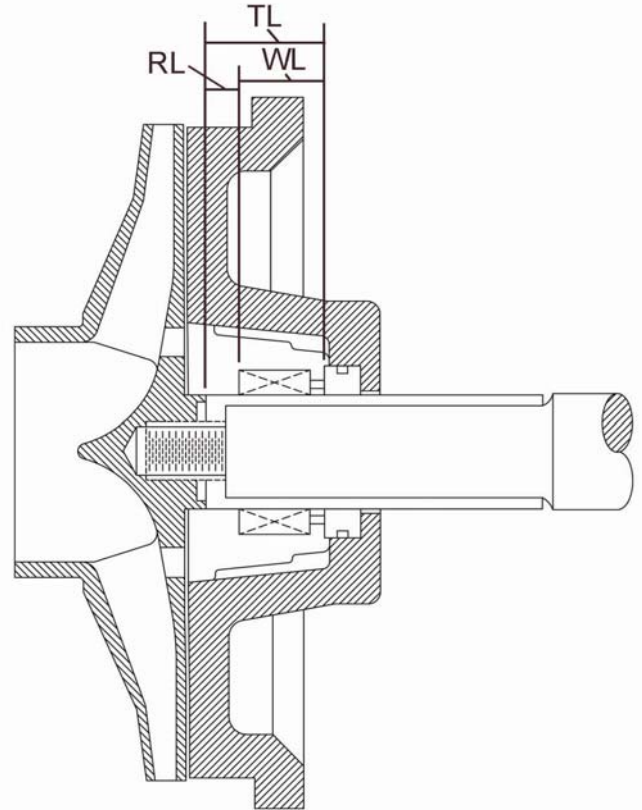
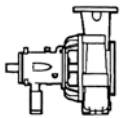

FIGURE 45 – FMI Seal Chamber



APPENDIX E

AMERICAN-MARSH OSD MAINTENANCE INSTRUCTIONS BEARING HOUSING OIL SEALS (LABYRINTH TYPE) INPRO/SEAL® VBXX BEARING ISOLATORS

INTRODUCTION

American-Marsh Pumps provides pumps fitted with a variety of labyrinth oil seals. While these instructions are written specifically for the Inpro/Seal VBXX labyrinth, they also apply to seals of other manufacturers. Specific installation instructions included with the seal, regardless of manufacturer, should be observed.

The Inpro “VBXX” Bearing Isolator is a labyrinth type seal which isolates the bearings from the environment (uncontaminated), and retains the oil in the bearing housing. The bearing isolator consists of a rotor and a stator. The rotor revolves with the shaft, driven by a close fitted drive ring that rotates with the shaft. The stator is a stationary component that fits into the housing bore with a press fit (nominal 0.002 in (0.05 mm) interference) and with an “O” ring gasket seal. The two pieces are assembled as a single unit, and are axially locked together by an “O” ring. There is no mechanical contact between the rotor and stator when the isolator is running.

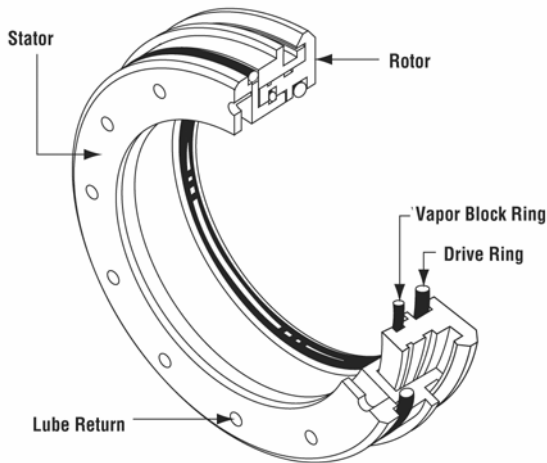

FIGURE 46 – Bearing Isolator

The VBXX is not intended to be separated from the bearing housing/adaptor/carrier unless being replaced.

1. If the VBXX is removed from the housing, for any reason, it must be replaced with a new VBXX to ensure a perfect seal with the housing bore.
2. Repair or replacement of the seals is only necessary when excessive oil leakage is evident. However, if for any other reason, the

bearing housing is to be disassembled or the pump shaft removed, it is recommended that the rotor “O” rings (which seal on the shaft) be replaced. Spare or replacement “O” rings may be obtained from “Inpro” distributors.

The “Inpro” VBXX bearing isolator is a one piece assembly. The rotor must not pull out of the stator. If the rotor can be removed, the complete seal assembly must be replaced.

3. If the bearing housing or bearing carrier with bronze VBXX seals is washed or cleaned using a caustic type bath, the bronze material may discolor (turn black). If this happens, the complete seal assembly must be replaced.

Note: This may occur if the housing is left in a caustic bath over a long period of time (more than 8 hours).

4. To remove the VBXX bearing isolator:
 - A. Remove the pump shaft as described in the pump disassembly instructions.
 - B. From the inside of the bearing housing or bearing carrier, place a bar (made from a soft material such as wood or plastic) against the inside face of the seal. Push the seal out by tapping the bar with a soft mallet or an arbor press.
5. To install a new VBXX bearing isolator, in the impeller end of the bearing housing/adaptor:
 - A. Position the impeller end (inboard) seal in the bore of the adapter or bearing housing with the **single expulsion port at the 6 o'clock position**, (carefully keep aligned with the bore).
 - B. The seal stator O.D. press fits into the bore. Use an arbor press. Place a block or bar (large enough to protect the rotor flange) between the arbor press ram and seal face. Press the seal down into the bore stopping at the shoulder on the stator O.D.

The elastomer “O” ring acts as a gasket to ensure damming up of small imperfections in the housing bore. The “O” ring is designed to be compressed to the point of overfilling its groove. The overfilled material is sheared off during assembly. Remove any sheared “O” ring material which may extrude from the bore.

6. To install a new VBXX bearing isolator in the drive end (outboard) side of the bearing carrier:
 - A. Position the outboard seal in the bore of the bearing carrier (no orientation of the multiple expulsion ports is necessary) and carefully keep aligned with the bore.

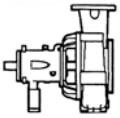

If the outboard seal has only one explosion port, that port must be oriented at the 6 o'clock position. Because the bearing carrier rotates for impeller adjustment, take the necessary steps to ensure the explosion port is oriented at 6 o'clock when the pump is installed and operating.

B. The seal stator O.D. press fits into the bore. Use an arbor press. Place a block or bar (large enough to protect the rotor flange) between the arbor press ram and seal face. Press the seal down into the bore stopping at the shoulder on the stator O.D. Remove any sheared o-ring material which may extrude from the bore.

7. Assemble the bearing carrier/VBXX bearing isolator on to the shaft:
 - A. On GP1 and GP2 pumps, the outboard double row bearing is nested inside of the bearing carrier, and retained in place by a snap ring. This **snap ring has a tapered edge on one side. The snap ring must be installed with the flat face of the snap ring against the bearing** and the tapered edge away from the bearing. On GP3 pumps, the bearing is held in place with a retaining ring fastened with cap screws.
 - B. Using sand paper, remove burrs and break any sharp edges off the keyway at end of the shaft.
 - C. It is important to prevent the corners of the keyway from cutting the "O" rings during assembly. This can be accomplished with the use of a half key or a thin flexible sleeve. Lightly lubricate the shaft and slide the bearing carrier on to the shaft, pushing on the VBXX rotor, until the bearing is seated. Assemble the bearing retainer snap ring.
 - D. Check the position of the rotor (make sure rotor and stator have not separated) and seat the rotor snugly into the stator by hand.
8. Assemble the shaft/bearings into the bearing housing:
 - A. **Screw a tapered cone into the impeller end of the shaft to act as a guide and to prevent from cutting the rotor "O" ring.**
 - B. Lightly lubricate the shaft and assemble the shaft into the bearing housing, sliding the shaft through the rotor, keeping the rotor seated snugly into the stator by hand.

- C. After the bearing carrier is screwed in place, rotate the shaft and check to make sure that both seal rotors are positioned snugly inside of the stators. If for some reason, the rotor becomes disengaged or is pushed completely out of the stator, the VBXX bearing isolator must be replaced. It is not advisable to force the rotor back into the stator.

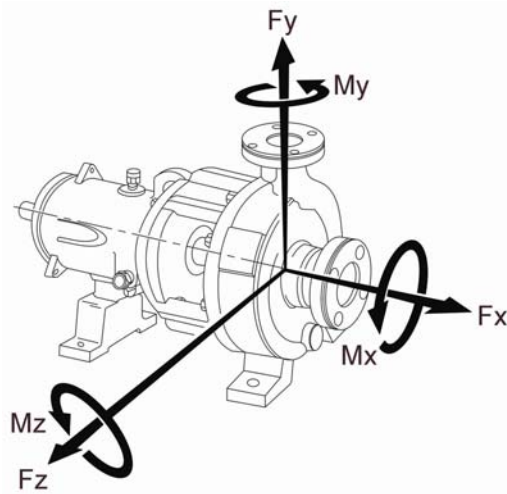
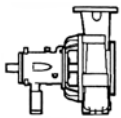

FIGURE 47 – Forces & Moments

APPENDIX F

ALLOWABLE NOZZLE LOADS OSD PUMPS (ASME B73.1M)

The allowable nozzle loads listed in Figure 52 may be applied to any OSD Standard Horizontal and Lo-Flo pumps in Ductile cast iron, Carbon Steel, 316 Stainless Steel, Cd4MCu, Monel, and Inconel. The allowable loads must be multiplied by 0.70 for pumps made of nickel, titanium, zirconium and high chrome iron.

The loads listed in Figure 48 are the combined values resolved to the center of the pump, except for the $F_r + M_r/3$ limits, which apply to the separate suction and discharge flanges. Some piping analysis programs calculate forces and moments on each flange, and do not translate them to a common point at the center of the pump. The formulas in Figure 50 and Dimensions in Figure 51 can be used to translate the forces and moments on each flange to the common center point.

Pump Nozzle Sizes	Combined Loading at Center of Pump						Flange Suction $F_{rs}+M_{rs}/3$	Loading Discharge $F_{rd}+M_{rd}/3$
	Forces (lbr)			Moments (lbr·ft)				
	F_x	F_y	F_z	M_x	M_y	M_z		
1 x 1.5	120	295	235	590	295	295	325	220
1.5 x 1.5	120	295	235	590	295	295	325	325
1 x 2	145	365	285	730	365	365	435	220
1.5 x 2	165	405	325	815	405	405	435	325
2 x 2	175	435	350	875	435	435	435	435
1.5 x 3	220	545	435	1090	545	545	650	325
2 x 3	235	590	470	1170	590	590	650	435
3 x 3	260	650	520	1300	650	650	650	650
3 x 4	325	815	650	1625	815	815	865	650
4 x 6	470	1170	940	2345	1170	1170	1300	865
6 x 8	610	1520	1215	3030	1520	1520	1730	1300
8 x 10	670	1670	1335	3350	1670	1670	1870	1730

FIGURE 48 – Forces & Moments (US Units)

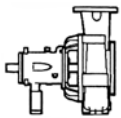

Pump Nozzle Sizes	Combined Loading at Center of Pump						Flange Suction Frs+Mrs*1.09	Loading Discharge Frd+Mrd*1.03
	Forces (N)			Moments (N•m)				
	Fx	Fy	Fz	Mx	My	Mz		
1 x 1.5	534	1313	1046	802	401	401	1446	979
1.5 x 1.5	534	1313	1046	802	401	401	1446	1446
1 x 2	645	1624	1268	993	496	496	1936	979
1.5 x 2	734	1802	1446	1108	551	551	1936	1446
2 x 2	779	1936	1558	1190	592	592	1936	1936
1.5 x 3	979	2425	1936	1482	741	741	2893	1446
2 x 3	1046	2626	2092	1591	802	802	2893	1936
3 x 3	1157	2893	2314	1768	884	884	2893	2893
3 x 4	1446	3627	2893	2210	1108	1108	3849	2893
4 x 6	2093	5207	4183	3189	1591	1591	5785	3849
6 x 8	2715	6764	5407	4121	2067	2067	7699	5785
8 x 10	2982	7432	5941	4556	2271	2271	8322	7699

FIGURE 49 – Forces & Moments (Metric Units)

Formula for all pumps
$F_x = F_{xs} + F_{xd}$
$F_y = F_{ys} + F_{yd}$
$F_z = F_{zs} + F_{zd}$
$M_x = M_{xs} + M_{xd} + (F_{zd} \cdot H) + (F_{zs} \cdot M)$
$M_y = M_{ys} + M_{yd} + (-F_{zs} \cdot L)$
$M_z = M_{zs} + M_{zd} + (F_{ys} \cdot L) - (F_{xd} \cdot H) - (F_{xs} \cdot M)$
$F_{rs} = \sqrt{(F_{xs}^2 + F_{ys}^2 + F_{zs}^2)}$
$M_{rs} = \sqrt{(M_{xs}^2 + M_{ys}^2 + M_{zs}^2)}$
$F_{rd} = \sqrt{(F_{xd}^2 + F_{yd}^2 + F_{zd}^2)}$
$M_{rd} = \sqrt{(M_{xd}^2 + M_{yd}^2 + M_{zd}^2)}$
Suction Loading (US Customary) = $F_{rs} + M_{rs}/3$
Discharge Loading (US Customary) = $F_{rd} + M_{rd}/3$
Suction Loading (Metric) = $F_{rs} + M_{rs} \cdot 1.09$
Discharge Loading (Metric) = $F_{rd} + M_{rd} \cdot 1.09$

FIGURE 50 – Load Translation Formula

Where:

Forces are expressed lbf or N and moments are expressed in lbf•ft or N•m.

Forces and Moments are positive in the directions shown on Figure 50.

F_x = Calculated total force in the x direction at the center of the pump.

F_{xs} = Force in the x direction applied to the suction nozzle.

F_{xd} = Force in the x direction applied to the discharge nozzle.

M_x = Calculated total moment about the x-axis at the center of the pump.

M_{xs} = Moment about the x-axis applied to the suction nozzle.

F_{rs} = Resultant force applied to the suction.

M_{rs} = Resultant moment applied to the suction.

H = Vertical distance from the centerline of the pump to the top of the discharge flange.

L = Horizontal distance from the centerline of the discharge to the front of the suction flange.

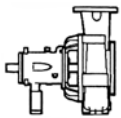

Pump Size	US Customary (Inches)			Metric (Meters)		
	H	L	M	H	L	M
1L1 x 1.5-6	6.5	4	0	0.165	0.102	0
1L1.5 x 3-6	6.5	4	0	0.165	0.102	0
1L2 x 3-6	6.5	4	0	0.165	0.102	0
1L1 x 1.5LF-4	6.5	4	0	0.165	0.102	0
1L1 x 1.5LF-8	6.5	4	0	0.165	0.102	0
1L1 x 1.5-8	6.5	4	0	0.165	0.102	0
1L1.5 x 3-8	7.5	4	0	0.191	0.102	0
2L2 x 3-8	9.5	4	0	0.241	0.102	0
2L3 x 4-8	11	4	0	0.279	0.102	0
2L1 x 2-10A	8.5	4	0	0.216	0.102	0
2L1 x 2LF-10	8.5	4	0	0.216	0.102	0
2L1.5 x 3-10A	8.5	4	0	0.216	0.102	0
2L2 x 3-10A	9.5	4	0	0.241	0.102	0
2L3 x 4-10	11	4	0	0.279	0.102	0
2L3 x 4-10H	12.5	4	0	0.318	0.102	0
2L4 x 6-10	13.5	4	0	0.343	0.102	0
2L4 x 6-10H	13.5	4	0	0.343	0.102	0
2L1.5 x 3-13	10.5	4	0	0.267	0.102	0
2L1.5 x 3LF-13	10.5	4	0	0.267	0.102	0
2L2 x 3-13	11.5	4	0	0.292	0.102	0
2L3 x 4-13	12.5	4	0	0.318	0.102	0
2L3 x 4-13HH	12.5	4	0	0.318	0.102	0
2L4 x 6-13A	13.5	4	0	0.343	0.102	0
3L6 x 8-14A	16	6	0	0.406	0.152	0
3L8 x 10-14	18	6	0	0.457	0.152	0
3L4 x 6-16	16	6	0	0.406	0.152	0
3L6 x 8-16A	18	6	0	0.457	0.152	0
3L8 x 10-16	19	6	0	0.483	0.152	0
3L8 x 10-16H	19	6	0	0.483	0.152	0
3L8 x 10-17	20	6	0	0.508	0.152	0

FIGURE 51 – Dimensions

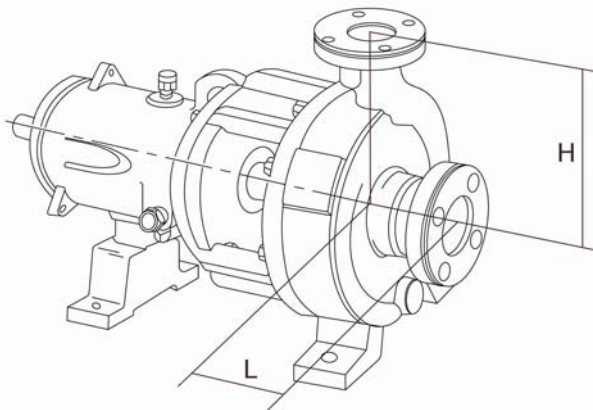

FIGURE 52 – OSD Dimensions