

# 3" Self-Priming Centrifugal Pumps

3" Self-Priming Pump w/ Optional Base



- **Cast Iron Construction with Stainless Steel Impeller**
- **Buna-N Mechanical Seal, Check Valve and O-Ring**
- **Optional Silicon Carbide Seal Available**
- **3" NPT Suction and Discharge Ports**
- **Maximum Solids Handling 3/8"**
- **Maximum Temperature 180° F**
- **Maximum Flow 352 GPM**
- **Maximum Head 110 Ft.**
- **Self-Priming to 20 Ft.**
- **Self-Cleaning, Semi-Open Impeller**
- **Solids Handling and Dirty Water Design**
- **3 to 7-1/2 HP TEFC, Single and Three Phase Motors**
- **Optional Mounting Base Available**

AMT Self-Priming Cast Iron Centrifugal pumps are designed for a broad range of high capacity applications, including dewatering, liquid transfer, circulation, drainage and irrigation. The centerline discharge feature is specifically designed to prevent vapor binding and makes for convenient piping connections. Pumps are designed to handle liquids with solids content or dissolved solids and debris. All models are fitted with self-cleaning, semi-open stainless steel impeller, which can handle 3/8" diameter semi-solids. Simple cleanout design permits easy removal of debris or drainage without disconnecting fittings. Built-in check valves for fast priming are standard on all units. Fill and drain plugs for easy installation and servicing.

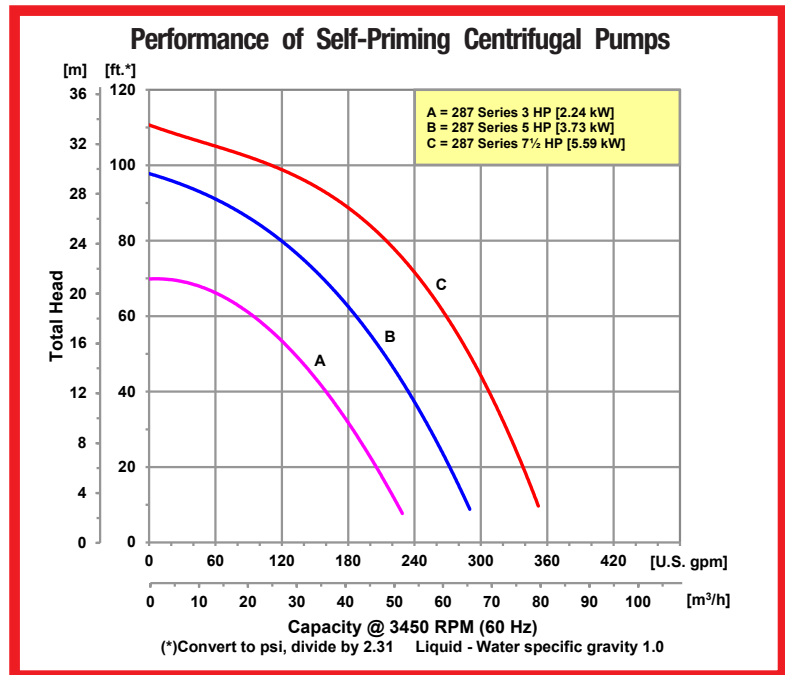

400 Spring Street • Royersford, PA 19468 USA

[www.amtpump.com](http://www.amtpump.com) • 888-amt-pump (268-7867)

For use with nonflammable liquids compatible with pump component materials. Viton® and Teflon® are registered trademarks of E. I. DuPont.

## Pump Dimensional & Specification Data

Model	Curve	HP	PH	Voltage @ 60 Hz +	Full Load Amps	Frame	SUC*	DIS*	A	B	C	L**	W**	H	Ship Wt. (Lbs.)
2877-95	A	3	1	230	16	184JM	3	3	3.7 [9.4]	17.1 [43.4]	5.5 [14.0]	29.1 [73.9]	13.7 [34.8]	11.8 [29.9]	133
2874-95			3	208-230/460	10/5	182JM			3.7 [9.4]	16.4 [41.6]	4.5 [11.4]	26.6 [67.6]	12.0 [30.5]	11.8 [29.9]	149
2878-95	B	5	1	230	21	184JM			3.7 [9.4]	17.1 [43.4]	5.5 [14.0]	29.1 [73.9]	13.7 [34.8]	11.8 [29.9]	205
2875-95			3	208-230/460	14/7	184JM			3.7 [9.4]	16.4 [41.6]	5.5 [14.0]	26.6 [67.6]	12.0 [30.5]	11.8 [29.9]	173
2879-95	C	7½	1	230	31	215JM			4.2 [10.6]	18.2 [46.2]	7.0 [17.8]	31.1 [79.0]	13.9 [35.3]	11.8 [29.9]	215
2876-95			3	208-230/460	20/10	184JM			3.7 [9.4]	16.4 [41.6]	5.5 [14.0]	26.6 [67.6]	12.0 [30.5]	11.8 [29.9]	176

(\*) Standard NPT (Female) pipe thread.

(\*\*) This dimension may vary due to motor manufacturer's specifications.

(+) 3-Phase motors can also operate on 50 Hz. (this will change full load amps, service factor and RPM)

NOTE: Dimensions are in inches (centimeters) and have a tolerance of  $\pm 1/4"$ .

NOTE: Electric supply for ALL motors must be within  $\pm 10\%$  of nameplate voltage rating (e.g. 230V  $\pm 10\%$  = 207 to 253)

Maximum Solids Handling Capacity: 3/8" Diameter

Optional Mounting Base  
Model A200-90

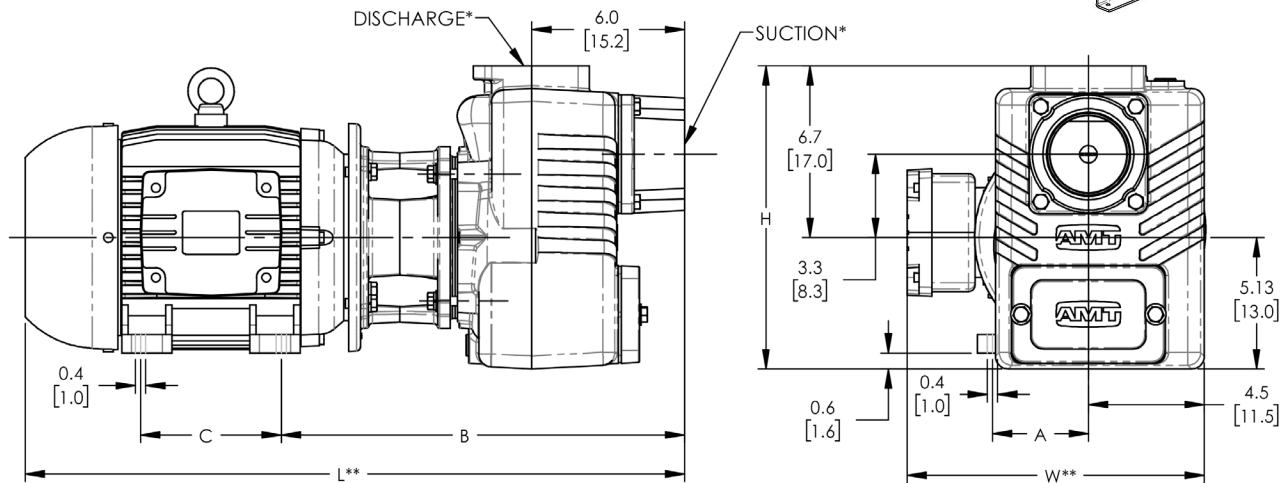
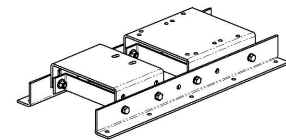

## Standard Features

- Cast Iron Construction with Stainless Steel Impeller
- Buna-N Mechanical Seal and O-ring
- Optional Viton® Mechanical Seal and Flapper Valve Available
- Optional Silicon Carbide Seal Available
- 3" NPT Suction and Discharge Ports
- Stainless Steel Sleeve
- Front Cleanout Cover Allows Easy Removal of Debris or Drainage w/o Disconnecting Fittings
- Fill and Drain Plug for Easy Servicing
- Maximum Working Pressure 125 PSI
- Maximum Temperature 180° F
- Maximum Flow 352 GPM
- Maximum Head 110 Ft.
- Self-cleaning, Semi-open Impeller
- 3 to 7½ HP Totally Enclosed Fan Cooled (TEFC) Single or Three Phase Motors
- Optional Mounting Base Available on All Above Models (A200-90)
- QSP – Quick Ship Pump for Many Models

**Hazardous Duty/Explosion Proof motors available from stock ranging from 1 to 10 HP; CALL FOR QUOTATION & LEAD TIME!**